

### Extended Pin

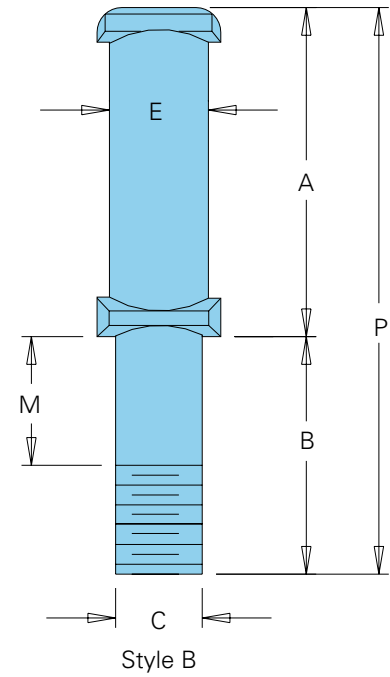

### S-22 Attachment

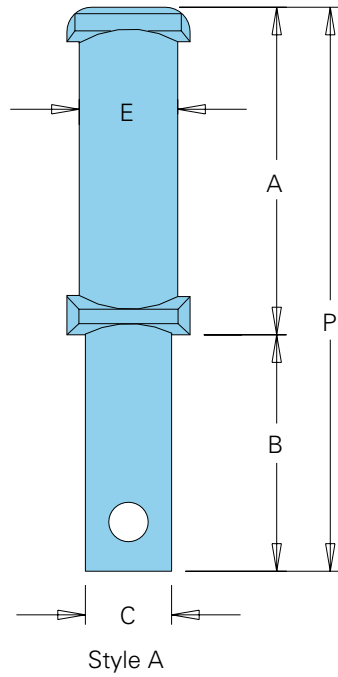
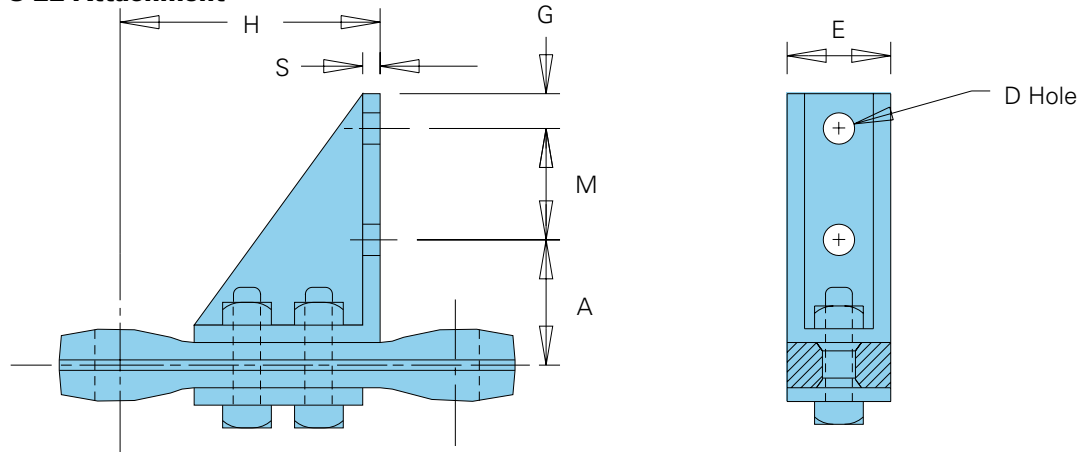

### Drop Forged Rivetless Chain Attachments

All dimensions are in inches unless otherwise indicated.

| Attach. Number            | Chain Number | A    | B    | C   | D   | E    | G   | H    | M    | P    | S   | Approx. Weight (lbs./ft.) |
|---------------------------|--------------|------|------|-----|-----|------|-----|------|------|------|-----|---------------------------|
| Extended Pin <sup>1</sup> | X-458        | 2.25 | 1.13 | .50 |     | .63  |     |      | .31  | 3.38 |     | .3                        |
|                           | X-678        | 3.13 | 1.50 | .75 |     | .88  |     |      | .19  | 4.63 |     | 1.5                       |
|                           | X-678        | 3.13 | 1.50 | .88 |     | .88  |     |      | .19  | 4.63 |     | 1.6                       |
|                           | 998          | 3.88 | 1.75 | .75 |     | 1.13 |     |      | .38  | 5.63 |     | 1.9                       |
| S-22                      | X-458        | 2.25 |      |     | .56 | 1.38 | .63 | 3.18 | 2.00 |      | .31 | 2.0                       |
|                           | X-678        | 2.88 |      |     | .68 | 1.81 | .88 | 4.75 | 2.25 |      | .31 | 4.7                       |

<sup>1</sup>Attachment pins also available with hexnut and lock washer.  
Attachments other than those shown available upon request.

To locate compatible sprockets for your chain, refer to the Product Cross-Reference in Section D.

Note: Dimensions are subject to change. Contact Union Chain to obtain certified prints for design and construction.

The following are examples of additional attachments available with Drop Forged Rivetless Chain. Attachments are also available for special applications.

**A-22 Attachment**

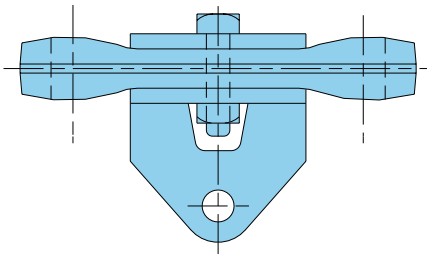

**F-2 Attachment**

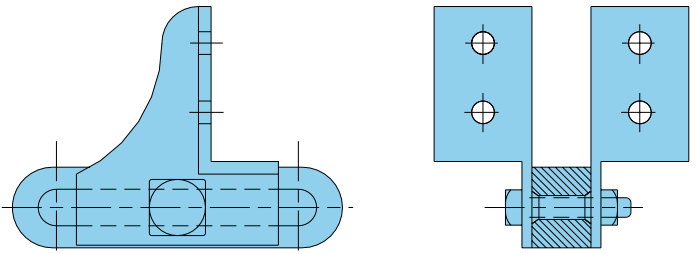

**A-53 Attachment**

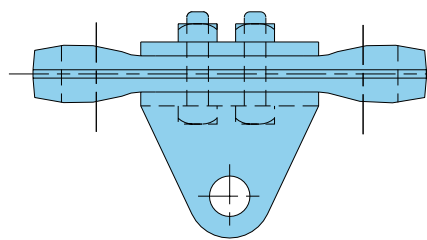

**K-2 Attachment**

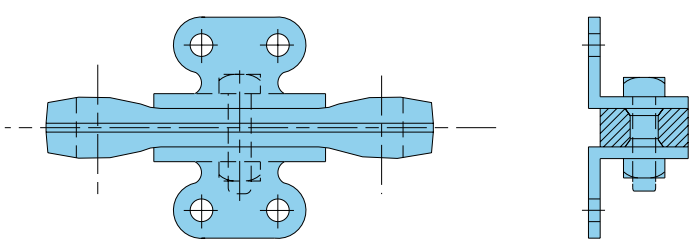

**Sprockets for Drop Forged Rivetless Chain**

Drop Forged Rivetless Sprockets are designed to work with the chain and attachments. Some setups, such as slider attachments on overhead slaughter house lines, require extra clearance that is not part of standard sprocket construction (Style 1).

Our specially developed sprocket (Style 2) has a "relief area". This keeps the chain from riding out of the sprocket pocket and reduces premature joint wear.

Select the right sprocket for your application. Contact Union Chain if you have any questions.

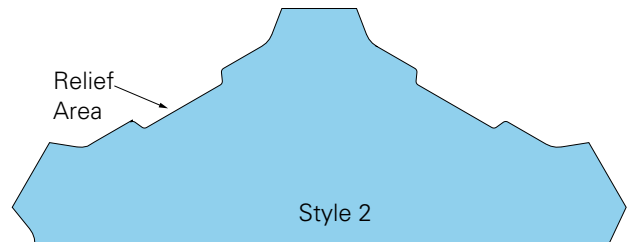
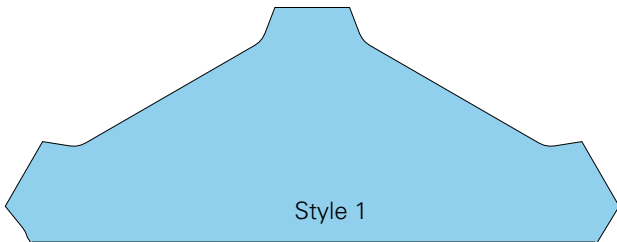

Standard sprockets are not designed for some applications like overhead slaughter house lines where the attachment requires extra clearance.

Drop Forged Rivetless Sprockets from Union have a "relief area" that allows for attachment protrusion. This means better articulation and longer wear life.