



APRON CONVEYORS

Move loose bulk materials like coal, lime, sand, stone, and sugar cane along horizontal or inclined conveyors. Apron Conveyors are especially useful as feeders to elevating systems, for picking tables and loading booms, and for long horizontal or inclined conveyors.

Create Custom Solutions

Union engineers will help you create a complete apron conveyor system for your application, including the right attachments, rollers, and lubrication packages to meet your specific requirements.

Apron Conveyors from Union

- Wide selection and styles.
- Customized for your application.
- Reliable, hassle-free operation.
- Cost-efficient value for your investment.

Choosing Metal Thickness

Experience is usually the best guideline for specifying the metal thickness for pans and aprons. Make sure you consider the following points.

1. Number of chain strands to be used.
2. Required service life.
3. Manufacturing restrictions.
4. Weight of each apron support. Deflection must be limited to prevent binding between overlapping pans.
5. Corrosive and abrasive properties of conveyed materials.

Applications Chart

Pan/Apron Suggested Thickness (inches)	Service Conditions	Material Handled
3/8	Heavy	Highly abrasive, corrosive or large impact loads
1/4 - 5/16	Medium	Moderately corrosive, abrasive or impact loads
3/16	Light	Mildly abrasive, corrosive or impact loads

Typical Arrangement—Apron Conveyors

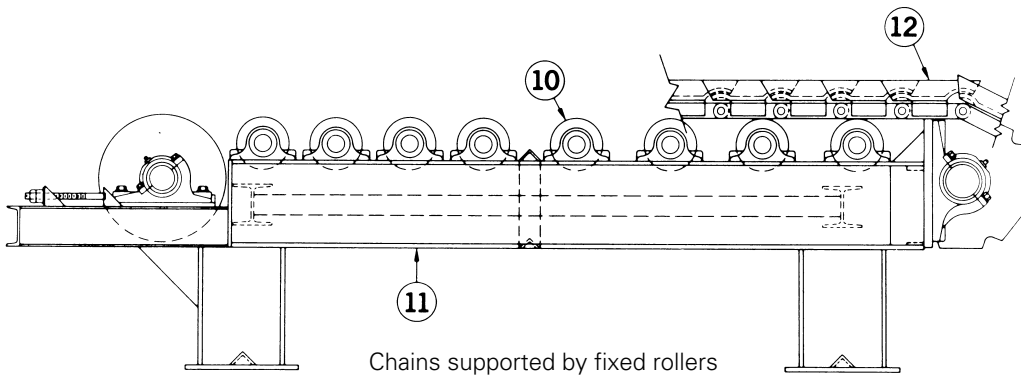
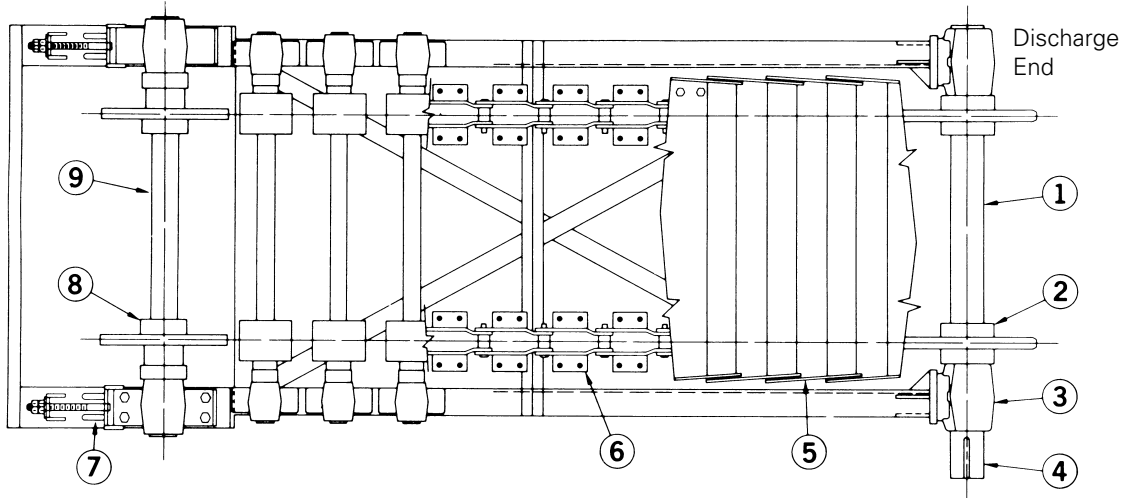

1. Head shaft — Discharge end.
2. Head shaft sprockets — Keyed to shaft.
3. Pillow blocks.
4. Drive end — Chain drive.
5. Apron assembly — Bolted to chain attachments.
6. Conveyor chain — Offset sidebar or straight sidebar (two or three strands normally used).
7. Take up — Normally located on tail shaft end.
8. Tail shaft sprockets — Only one keyed to shaft (other sprockets locked in place with collars).
9. Tail shaft.
10. Intermediate rollers — Supports chain sections when conveyor is heavily loaded.
11. Conveyor structure.
12. Pan ends — Welded to aprons.
13. Stationary sideboards — Offer additional capacity.

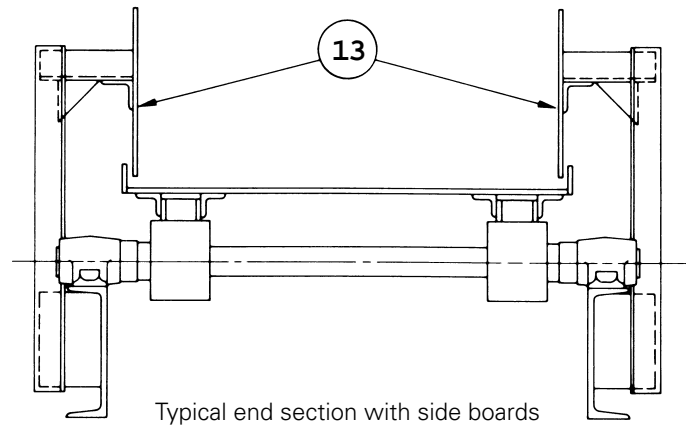

Style A

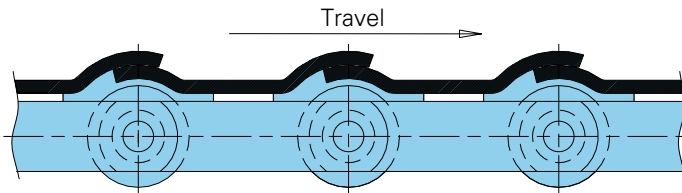
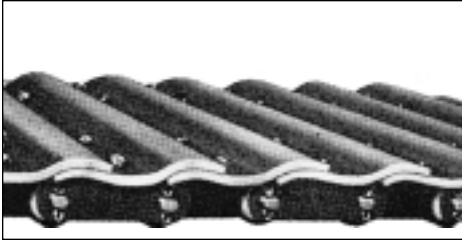

Uses

- Adaptable for any pitch conveyor.
- Most widely used style for horizontal or incline applications up to 35 degrees.

Advantages

- More leakproof than other styles of apron conveyor.
- With K attachments, the load is distributed evenly on both chains.
- Pan ends, when needed, fasten directly to apron and not to chain.

Attachments

- A attachments (one side of chain only) for long center distances.
- K attachments (both sides of chain) for short center distances.

Style A — Outboard Roller Support (OBR)

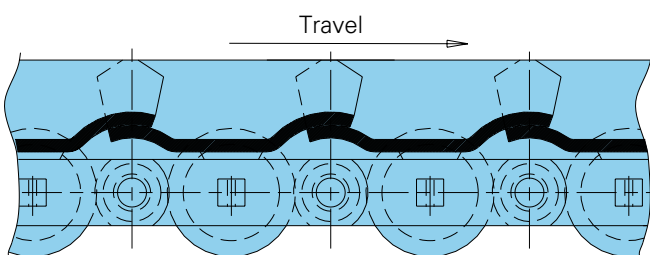
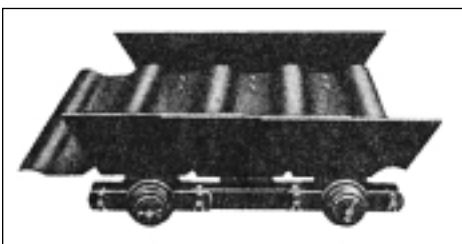

Uses

- Handles fine abrasive materials on incline applications up to 35 degrees.
- Longer pitch conveyors with two strands of chain mounted below and close to the ends of the pans.

Advantages

- Close-fitting members hold leakage to a minimum, protecting the conveyor and avoiding damage when handling abrasives.
- Reduced maintenance costs because outboard rollers may be removed for inspection or renewal without dismantling chains or pans.
- Conveyed load is carried on outboard rollers.
- Head shaft terminal load is carried on chain rollers.

Attachments

- A-2, E-2, M-1 attachments are commonly used.

Style A — Fixed Roller Support

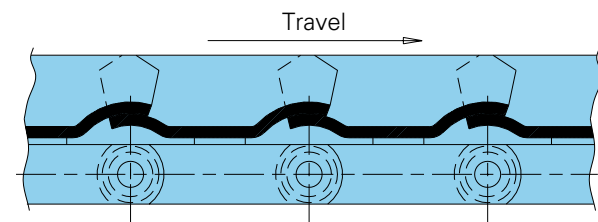
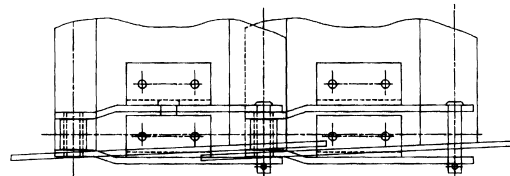

Uses

- Handles heavy conveyed materials.
- Withstands high-impact loads.

Advantages

- Chain is supported under sidebars by fixed frame rolls that transfer load instead of chain joint rollers.
- The close-fitting members keep leakage to a minimum, protecting your equipment from abrasives.

Attachments

- K attachments usually improve load distribution.
- K-1, K-2, A-1, A-2, E-2 attachments are commonly used.

Style B

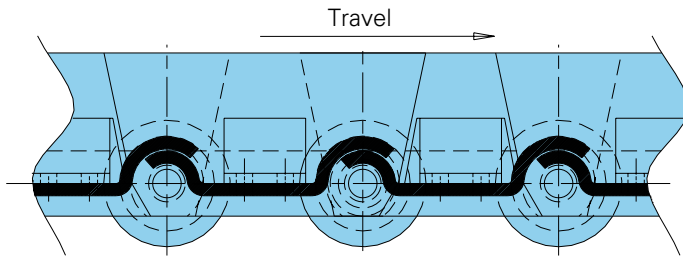
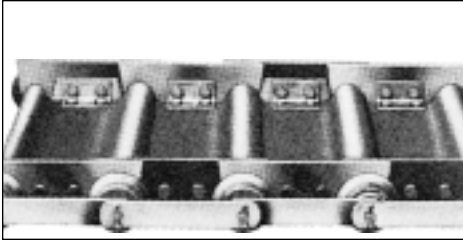

Uses

- Suitable for heaviest duty conditions; generally used in longer pitch conveyors.
- Adaptable to various service and operational conditions for horizontal or incline applications as much as 35 degrees.

Advantages

- Deep beads form a rigid pan for heavy loads on wide conveyors.
- Chain rollers permit return strand to roll on a track.
- Through-rods and load deflection rail supports may be used to prevent excessive chain loading under heavy impact conditions.

Attachments

- G-2 attachments (high sidebars with angles) contain material, add strength, and function as moving pan ends.

Style D

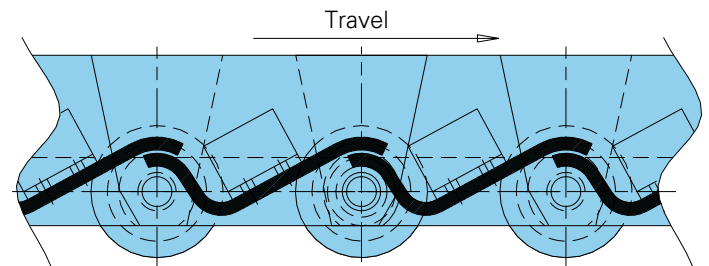
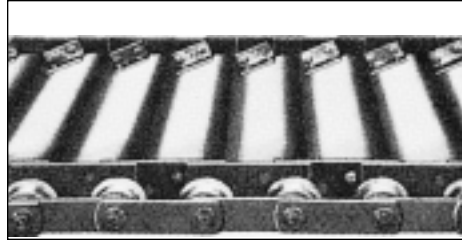

Uses

- Positive discharge aprons.
- Adaptable to various service and operating conditions for horizontal or incline applications as much as 35 degrees.

Advantages

- Higher angle of discharge reduces height of fall when unloading, reducing lump breakage.
- Angular mounting of apron on chain helps resist rollback motion of material on inclined conveyors.

Attachments

- G-2 attachments (high sidebars with angles) contain material, add strength, and function as moving pan ends.

Style A Aprons

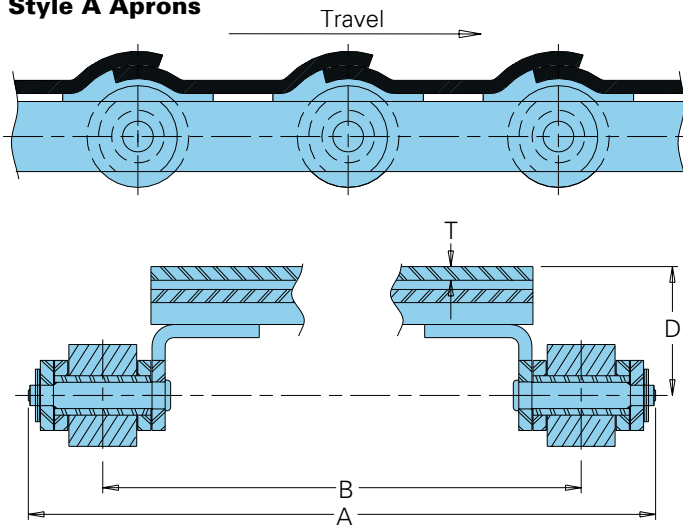

Style A-OBR Aprons

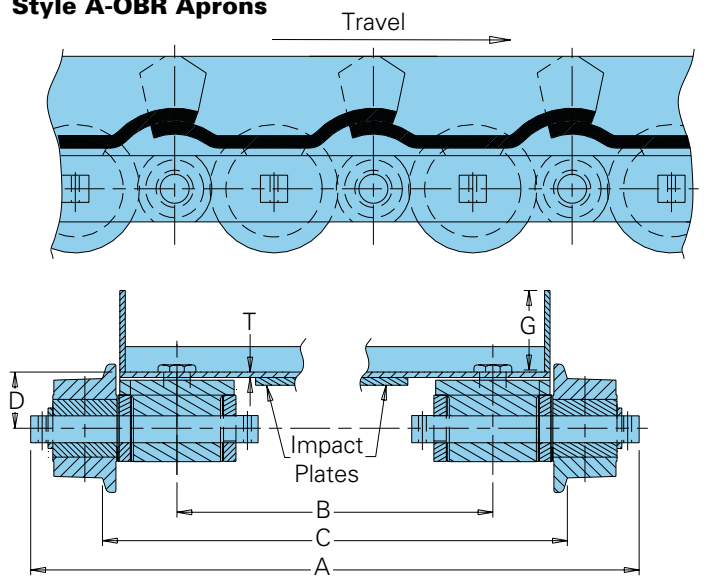

Style A-FRS Aprons

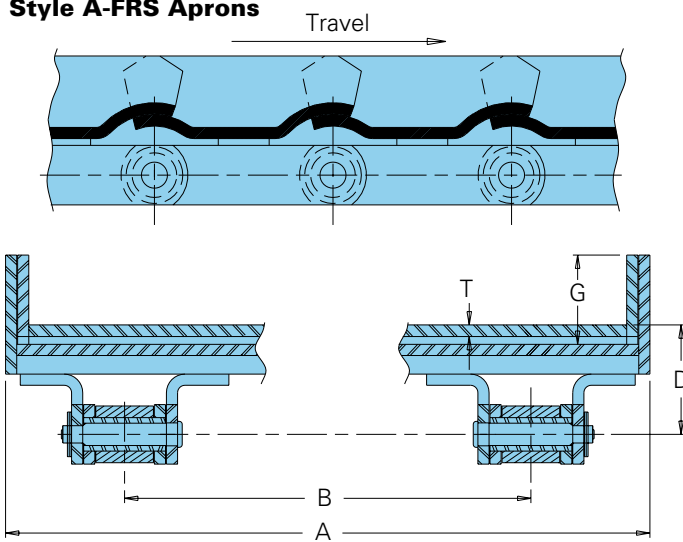

Style B Aprons

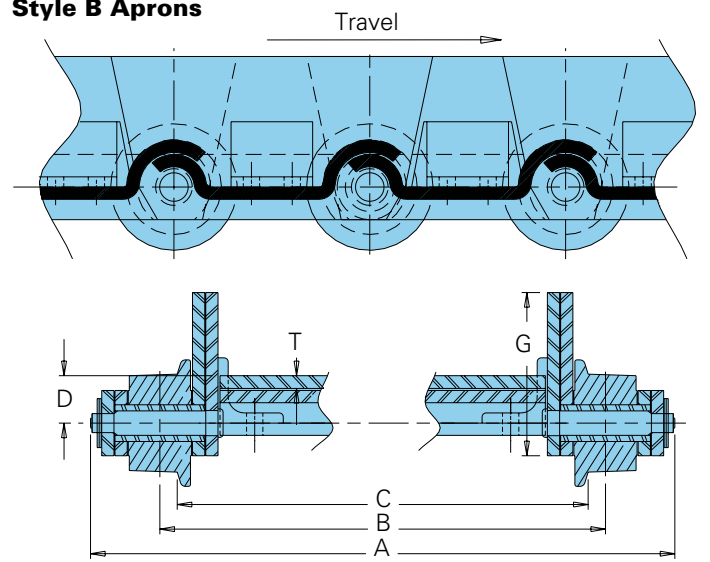

Style D Aprons

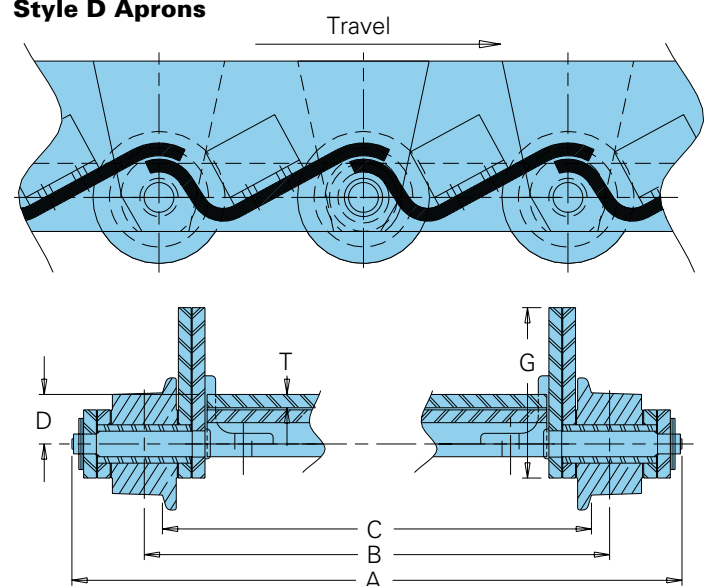

Apron Conveyors

All dimensions are in inches unless otherwise indicated.

Style	Chain Number	Pitch	Width ¹			Centerline Chain to Top of Pan Bead	Pan End Height	Pan Th.	Work Load (lbs.) ²	Approximate Weight (lbs.)		
			Overall	Center to Center Sprocket	Track Gauge					Conveyor Weight (ft.) 18" Pan ³	Approx. Wgt. Each 1" Added to Height	Weight Added Each 6" of Width
			A	B	C	D	G	T				
Style A Aprons	95R	4.000	21.88	19.38		2.00		.19	4,200	24.2		3.8
	US-90R	4.000	21.44	19.56		2.00		.19	4,800	28.0		3.8
	US-90R	4.000	21.44	19.56		2.06		.25	4,800	33.7		5.1
	89R	4.000	23.94	20.06		2.06		.25	9,000	44.3		5.1
	89R	4.000	23.94	20.06		2.31		.31	9,000	50.0		6.4
	89R	4.000	23.94	20.06		2.38		.38	9,000	55.7		7.7
	604R	6.000	23.00	19.81		2.19		.19	7,000	27.0		5.4
	631R	6.000	24.19	20.13		2.25		.25	11,200	43.0		7.2
	631R	6.000	24.19	20.13		2.31		.31	11,200	48.6		9.0
	610R	6.000	24.81	20.44		2.88		.38	14,900	59.6		10.8
Style A OBR Aprons ⁴	961R	9.000	28.06	14.75	22.56	2.88	4.00	.25	18,000	115.2	2.9	8.3
	2397R	12.000	27.25	15.19	21.81	3.75	4.00	.25	18,400	92.5	2.6	7.5
	1706R	12.000	28.06	14.75	22.56	3.75	4.00	.25	28,000	108.7	2.6	7.5
	2614R	12.000	27.69	14.19	22.06	4.25	4.00	.25	35,000	157.1	2.6	7.5
	2614R	12.000	27.69	14.19	22.06	4.38	4.00	.38	35,000	172.4	4.0	11.3
Style A FRS	961R	9.000	19.25	14.75 max.		2.88	4.00	.25	18,000	61.5	2.9	8.3
	2614R	12.000	19.75	14.19 max.		4.38	4.00	.38	35,000	76.6	4.0	11.3
Style B Aprons	603R	6.000	23.69	20.75	20.13	1.06	3.50	.19	7,000	40.5	3.0	5.4
	625R	6.000	24.63	21.16	20.31	1.06	3.50	.19	8,300	43.4	3.0	5.4
	625R	6.000	24.63	21.16	20.31	1.13	3.50	.25	8,300	48.8	3.0	7.2
	625R	6.000	24.63	21.16	20.31	1.19	4.00	.31	8,300	55.6	3.0	9.0
	B-663R	6.000	26.38	22.13	21.13	1.13	3.50	.25	14,400	56.0	4.6	7.2
	B-663R	6.000	26.38	22.13	21.13	1.19	4.00	.31	14,400	63.2	4.6	9.0
	B-963R	9.000	26.38	22.13	21.13	1.38	4.00	.25	14,400	56.7	4.6	7.1
	B-963R	9.000	26.38	22.13	21.13	1.44	4.00	.31	14,400	60.0	4.6	8.2
	B-963R	9.000	26.38	22.13	21.13	1.75	4.00	.38	14,400	67.3	4.6	10.6
	B-964R	9.000	26.88	22.44	21.19	1.44	4.00	.31	18,400	66.7	4.2	8.2
	B-964R	9.000	26.88	22.44	21.19	1.75	5.00	.38	18,400	78.1	4.2	10.6
	B-1263R	12.000	26.38	22.13	21.13	1.38	4.00	.25	14,400	53.1	3.8	7.0
	B-1263R	12.000	26.38	22.13	21.13	1.44	4.00	.31	14,400	58.3	3.8	8.8
	B-1263R	12.000	26.38	22.13	21.13	1.75	4.00	.38	14,400	63.6	3.8	10.5
	B-1264R	12.000	26.88	22.44	21.19	1.44	4.00	.31	18,400	61.5	3.8	8.8
	B-1264R	12.000	26.88	22.44	21.19	1.75	5.00	.38	18,400	70.6	3.8	10.5
Style D Aprons	625R	6.000	24.63	21.16	20.31	1.06	3.50	.19	8,300	43.4	3.0	5.4
	625R	6.000	24.63	21.16	20.31	1.13	3.50	.25	8,300	48.8	3.0	7.2
	625R	6.000	24.63	21.16	20.31	1.19	4.00	.31	8,300	55.6	3.0	9.0
	B-963R	9.000	26.38	22.13	21.13	1.38	4.00	.25	14,400	56.7	4.6	7.1
	B-963R	9.000	26.38	22.13	21.13	1.44	4.00	.31	14,400	60.0	4.6	8.2
	B-963R	9.000	26.38	22.13	21.13	1.75	4.00	.38	14,400	67.3	4.6	10.6
	B-964R	9.000	26.88	22.44	21.19	1.44	4.00	.31	18,400	66.7	4.2	8.2
	B-964R	9.000	26.88	22.44	21.19	1.75	5.00	.38	18,400	78.1	4.2	10.6
	B-1263R	12.000	26.38	21.13	21.13	1.38	4.00	.25	14,400	53.1	3.8	7.0
	B-1263R	12.000	26.38	21.13	21.13	1.44	4.00	.31	14,400	58.3	3.8	8.8
	B-1263R	12.000	26.38	21.13	21.13	1.75	4.00	.38	14,400	63.6	3.8	10.5
	B-1264R	12.000	26.88	22.44	21.19	1.44	4.00	.31	18,400	61.5	3.8	8.8
	B-1264R	12.000	26.88	22.44	21.19	1.75	5.00	.38	18,400	70.6	3.8	10.5

¹All widths and weights are based on 18" apron pan widths. For weight est. refer to "Approximate Weight (lbs.)" column for your specific conveyor width.

²Indicates working load for two strands of chain.

³Indicates without through-rods. Refer to page A-42 for rod weights.

⁴OBR style can be furnished stub shaft every pitch or every 2nd pitch depending on load criteria. All weights shown above are for OBR every pitch. Consult with Union engineers for selection assistance.

To locate compatible sprockets for your chain, refer to the Product Cross-Reference in Section D.

Note: Dimensions are subject to change. Contact Union Chain to obtain certified prints for design and construction.

Apron Conveyor Dimensions

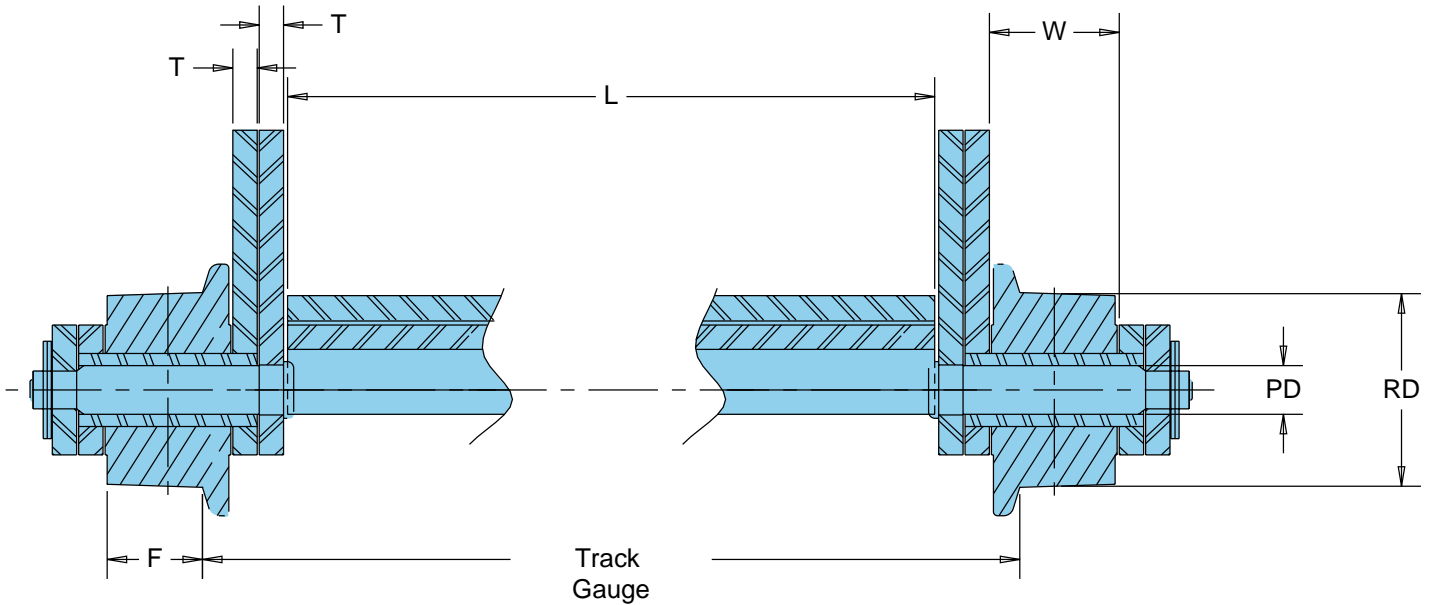

Apron Conveyor Dimensions for Chain with Single Flange Rollers Styles B & D Conveyors

Center to Center of chain = $L + 4T + W + 3/16"$

Track Gauge = $L + 4T + 2k + 1/2"$

Center to Center of sprocket = $L + 4T + 2k + F + 1/4"$

Overall Width = $L + 8T + 2W + 2c + 1/4"$

Where:

L = Length of apron

T = Thickness of sidebars (chain dimension)

W = Inside width (chain dimension)

F = Width or face of roller tread

k = Constant for diameter of roller

c = Constant for diameter of pin

Values of F and k

Roller Diam. RD	F	k
2.50	.88	.31
3.00	1.09	.41
3.00	1.25	.31
3.50	1.25	.56
4.00	1.25	.59
4.00	1.50	.59
5.00	1.75	.66
5.00	1.75 ¹	.72
6.00	1.88	.69
6.00	1.88 ¹	.81

¹Indicates heavier wheel of same width of roller tread.

Values of c

Pin Diam. PD	c
.56	.41
.63	.47
.75	.56
.88	.56
1.00	.69
1.13	.69
1.25	.69
1.50	.81

Apron Weights/Each Unassembled

All dimensions are in inches unless otherwise indicated.

Pitch	Thickness	Approximate Weight (lbs.)											
		18"	24"	30"	36"	42"	48"	54"	60"	66"	72"	78"	84"
3.000 ¹	.19	4.3	5.7	7.2	8.6	10.0	11.5	12.9	14.3	15.7	17.2	18.6	20.0
4.000 ¹	.19	5.8	7.7	9.6	11.5	13.4	15.3	17.3	19.2	21.1	23.0	24.9	26.8
4.000 ¹	.25	7.7	10.2	12.7	15.3	17.8	20.4	23.0	25.5	28.0	30.6	33.2	35.7
4.000 ¹	.31	9.6	12.8	16.0	19.2	22.4	25.6	28.8	31.9	35.1	38.3	41.5	44.7
4.000 ¹	.38	11.5	15.3	19.1	23.0	26.8	30.6	34.4	38.3	42.0	45.9	49.8	53.6
6.000	.19	8.1	10.8	13.5	16.4	19.0	21.7	24.4	27.1	29.8	32.5	35.2	38.0
6.000	.25	10.8	14.5	18.1	21.7	25.3	28.9	32.6	36.2	39.8	43.5	47.0	50.6
6.000	.31	13.6	18.1	22.6	27.1	31.6	36.2	40.7	45.2	49.7	54.2	58.8	63.3
6.000 ¹	.38	16.3	21.7	27.2	32.5	38.0	43.4	48.7	54.2	59.6	65.0	71.5	76.0
6.000 ¹	.50	21.7	28.9	36.1	43.4	50.6	57.9	65.0	72.3	79.4	86.6	93.9	101.0
9.000	.19	12.0	16.0	20.0	24.0	28.0	32.0	36.0	40.0	44.0	48.0	52.0	56.0
9.000	.25	16.0	21.2	26.6	31.9	37.2	42.5	47.9	53.2	58.5	63.8	69.0	74.5
9.000	.31	18.4	24.6	30.7	36.9	43.0	49.1	55.3	61.5	67.6	73.8	80.0	86.1
9.000	.38	23.9	31.9	39.8	47.8	55.8	63.7	71.7	79.7	87.7	95.7	103.6	111.6
12.000 ²	.19	15.8	21.0	26.3	31.6	37.9	42.1	47.4	52.6	58.0	63.2	68.5	73.8
12.000 ²	.25	21.1	28.1	35.1	42.1	49.1	56.1	63.1	70.1	77.1	84.1	91.1	98.1
12.000 ²	.31	26.3	35.1	43.9	52.6	61.4	70.2	79.0	87.7	96.5	105.2	113.9	122.7
12.000 ²	.38	31.6	42.2	52.7	63.2	73.8	84.4	94.8	105.2	115.9	126.3	136.9	147.5

¹Style A aprons only.

²Style B aprons only.

Steel Pan Ends

Separate Steel Pan Ends Approximate Weight (lbs.)						
Chain Pitch	Thick. of Ends	Unassembled Height of End Above Center Line of Chain				
		2"	3"	4"	5"	6"
3.000	.19	.7	.8	.9	1.0	1.3
4.000	.19	.6	.8	1.3	1.5	1.7
4.000	.25	.8	1.1	1.7	2.0	2.3
6.000	.19	1.0	1.3	1.8	2.1	2.4
6.000	.25	1.4	1.9	2.4	2.9	3.3

Through-Rod Weights

Approximate Weight/Through-Rods (lbs.)								
Chain Pin Dia.	Distances Between Centers							
	18"	24"	30"	36"	42"	48"	54"	60"
.63	1.6	2.1	2.6	3.0	3.7	4.2	4.7	5.2
.75	2.3	3.0	3.8	4.5	5.3	6.0	6.8	7.5
.88	3.1	4.1	5.1	6.1	7.1	8.1	9.1	10.1
1.00	4.0	5.4	6.7	8.0	9.4	10.7	12.0	13.4
1.13	5.1	6.8	8.5	10.2	11.8	13.5	15.2	16.9
1.25	6.3	8.4	10.4	12.5	14.6	16.7	18.8	21.9
1.50	9.0	12.0	15.0	18.0	21.0	24.0	27.0	30.0

Note: Through-rods are made from high carbon steel. The portions of the ends that act as chain pins are heat-treated for wear resistance.