

ACS Type Heavy Duty Collector Chains

ACS Type Chains were specially developed for sand and dirt scrapers and conveyors. All components are constructed of high-quality stainless steel and through-hardened by heat-treatment before assembly. The link plates, pins, and bushings are press-fitted in order to ensure not only reliability against lateral and impact loads, but also protection against loosening caused by impact load cycles. ACS Type Chains provide long wear life and corrosion resistance.

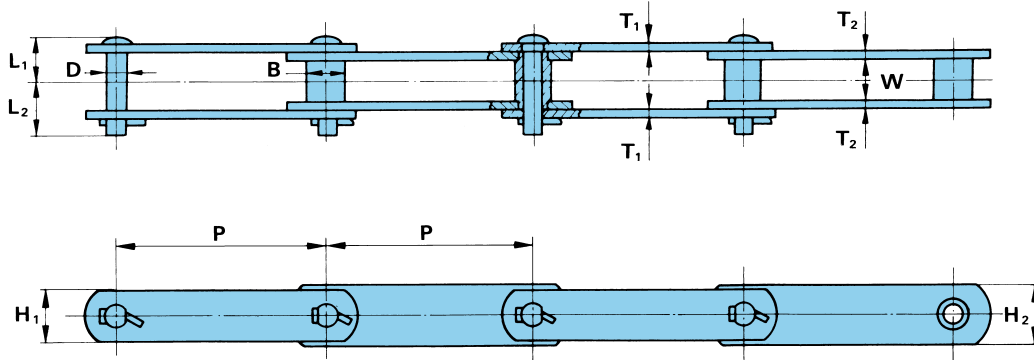

Benefits

- Excellent press fit
- Impact load protection
- Long-wear
- Corrosion resistant

ACS Type Heavy Duty Collector Chain Specifications

All dimensions are in inches unless otherwise indicated.

Chain Number	Average Tensile Strength (lbs.)	Pitch	Width Between Inner Link Plates	Bushing		Pin		Link Plate				Approx. Weight (lbs./ft.)
				B	D	L ₁	L ₂	T ₁	T ₂	H ₁	H ₂	
ACS13078W	29,700	3.075	1.024	.906	.500	1.102	1.260	.197	.197	1.299	1.417	3.49
ACS13103W	29,700	4.063	1.024	.906	.500	1.102	1.260	.197	.197	1.299	1.417	3.08
ACS13152W	29,700	6.000	1.024	.906	.500	1.102	1.260	.197	.197	1.299	1.417	2.41
ACS15152W	33,000	6.000	1.024	.945	.531	1.142	1.299	.197	.236	1.417	1.496	3.22
ACS19152W	41,900	6.000	1.181	1.024	.571	1.260	1.555	.236	.236	1.496	1.732	3.89
ACS25152W	55,100	6.000	1.181	1.142	.622	1.378	1.614	.236	.276	1.732	2.126	5.30
ACS35152W	77,100	6.000	1.496	1.378	.748	1.614	1.811	.276	.276	2.126	2.362	7.31

Note: Offset links are also available upon request.

Standard coating is for sewage treatment. If used in other applications, please call for more information.

To locate compatible sprockets for your chain, refer to the Product Cross-Reference in Section D.

Note: Dimensions are subject to change. Contact Union Chain to obtain certified prints for design and construction.

"SF-4" Attachment

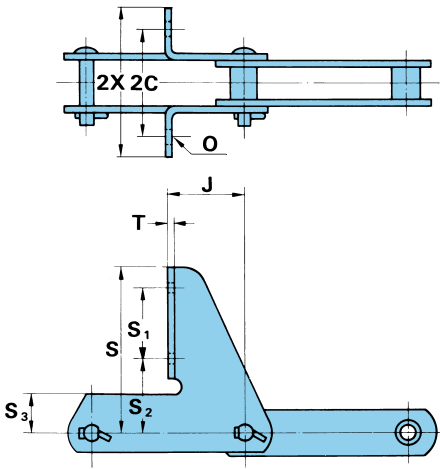

"LA-1" Attachment

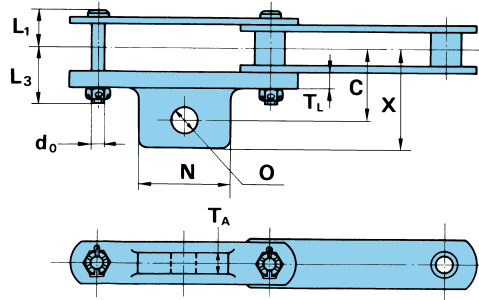

Long Pin Attachment

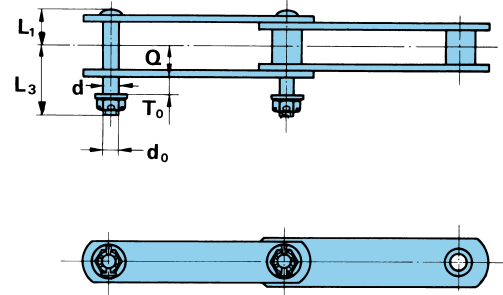

Heavy Duty Collector Chain Attachment Specifications

All dimensions are in inches unless otherwise indicated.

Attachment Style	Chain Number										Add'l. Weight (lbs./att.)
		2C	2X	J	S	S ₁	S ₂	S ₃	O	T	
SF-4	ACS13078W	3.543	5.177	1.496	4.331	1.378	2.165	1.102	.551	.197	1.32
SF-4	ACS13103W	3.543	5.177	2.047	4.331	1.378	2.165	1.102	.551	.197	1.54
SF-4	ACS13152W	3.543	5.177	2.992	4.331	1.378	2.165	1.102	.551	.197	2.20
SF-4	ACS15152W	3.937	5.650	2.992	6.102	2.559	2.756	1.378	.551	.197	2.64
SF-4	ACS19152W	3.937	5.571	2.992	6.181	2.559	2.756	1.496	.551	.236	3.08
SF-4	ACS25152W	3.937	5.650	2.992	6.063	2.559	2.756	1.496	.551	.236	3.08
SF-4	ACS35152W	4.331	5.984	2.992	6.299	2.559	2.953	1.575	.551	.276	3.52

Attachment Style	Chain Number										Add'l. Weight (lbs./att.)
		d ₀	L ₁	L ₃	C	X	N	O	T _A	T _L	
LA-1	ACS13078W	M10	1.161	1.634	2.165	3.031	1.575	.748	.630	.472	.88
LA-1	ACS13103W	M10	1.161	1.634	2.165	3.031	2.205	.748	.630	.472	1.32
LA-1	ACS15152W	M12	1.201	1.752	2.165	3.031	2.677	.748	.630	.472	1.76
LA-1	ACS19152W	M12	1.319	2.208	2.559	3.543	3.150	.945	.787	.630	2.64
LA-1	ACS25152W	M14	1.437	2.106	2.559	3.543	3.150	.945	.787	.630	3.08
LA-1	ACS35152W	M16	1.673	2.421	2.953	4.016	3.150	1.024	.945	.748	4.40

Attachment Style	Chain Number							Add'l. Weight (lbs./att.)
		d	d ₀	L ₁	L ₃	Q	T ₀	
Long Pin	ACS13078W	.472	M10	1.102	1.929	.945	.472	.13
Long Pin	ACS13103W	.472	M10	1.102	1.929	.945	.472	.13
Long Pin	ACS15152W	.512	M12	1.142	2.008	.984	.472	.22
Long Pin	ACS19152W	.551	M12	1.260	2.323	1.102	.630	.24
Long Pin	ACS25152W	.610	M14	1.378	2.441	1.142	.630	.31
Long Pin	ACS35152W	.728	M16	1.614	2.835	1.346	.748	.44

To locate compatible sprockets for your chain, refer to the Product Cross-Reference in Section D.

Note: Dimensions are subject to change. Contact Union Chain to obtain certified prints for design and construction.