



Asphalt Batch Plants & Finishing

We make a variety of chains for the asphalt and paving industry. The combination of hard aggregates, asphalt, and the necessity to run almost continuously during the paving season calls for tough chains with long wear life. The Union Chain Division of U.S. Tsubaki, Inc., supplies chains that meet these demanding requirements.



Paving Machines

When hot asphalt arrives at a road construction site, the mix flows from dump trucks into the paving machine hopper. An asphalt paving machine uses a special scraper conveyor to transfer hot asphalt from the hopper to the road surface. We have designed chains specifically to fit O.E.M. equipment and to function in this hot, abrasive environment.

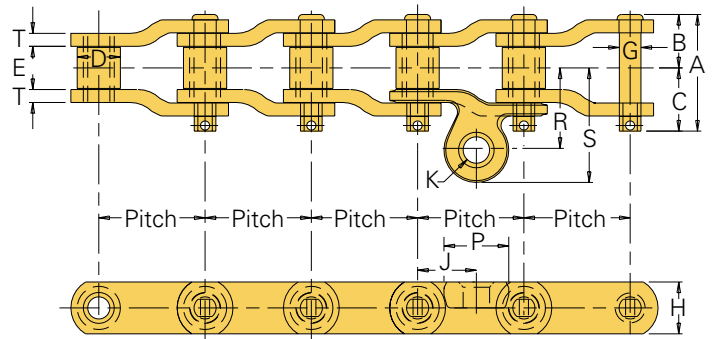

Paver Chains

All dimensions are in inches unless otherwise indicated.

Dwg. No.	Pitch	Width				Roller	Pin	Sidebar			Attachment					Bearing Area (in. ²)	Average Ultimate Strength (lbs.)	Work Load (lbs.)	Approx. Weight (lbs./ft.)
		Overall	Pin Head to CL	Pin End to CL	Inside			Dia.	Hgt.	Th.	Rivet Dia.	J	R	S	K				
		A	B	C	E	D	G	H	T	P	J	R	S	K					
21460	3.075	3.37	1.55	1.83	1.25	1.25	.63	1.50	.38	1.97	1.70	2.31	3.30	1.02	1.09	56,900	4,375	7.5	
20842	3.075	3.37	1.55	1.83	1.25	1.25	.63	1.50	.38	1.88	1.70	2.38	3.31	.77	1.09	56,900	4,375	7.6	

Indicates this chain is normally stocked. All others are made-to-order.

Asphalt Plants

Three types of chains are typically used in asphalt plants:

- Inclined Scraper Conveyor Chains are used to move the asphalt mix into storage hoppers.
- Drive Chains are used on rotating drums to mix the aggregate and asphalt.
- Bucket Elevator Chains are used to move aggregates to storage silos and are sometimes used to move the asphalt mix to storage hoppers.

The Union Chain Division supplies Inclined Scraper Conveyor Chains in 4" to 6" pitch with both K- and slotted-M-style attachments. These chains are designed and constructed to give the best combination of strength and toughness. The chains are balanced to ensure continued safe operation. Sidebars are hardened to resist the impact loading that may occur. Rollers are specially heat-treated to resist outside diameter abrasion inherent in asphalt conveyors. These special features make our chains long-lasting and keep your operation running smoothly.

K-11 Style Attachment

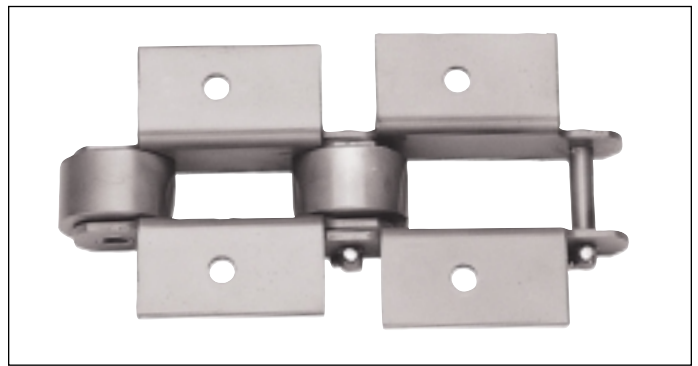
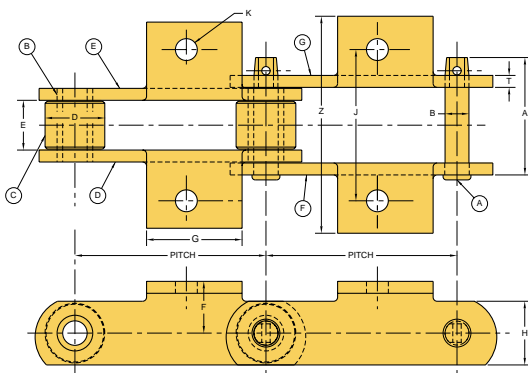

K-1/K-2 or K-3 Style Attachment

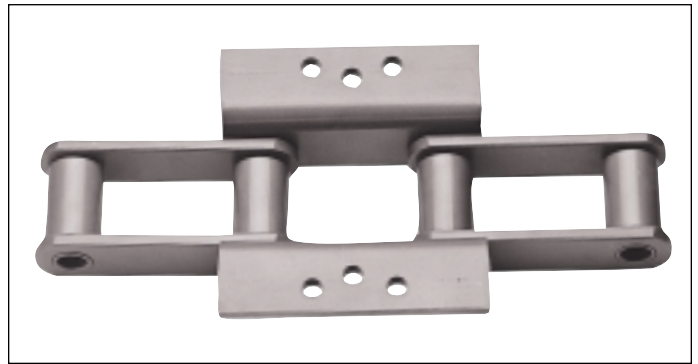
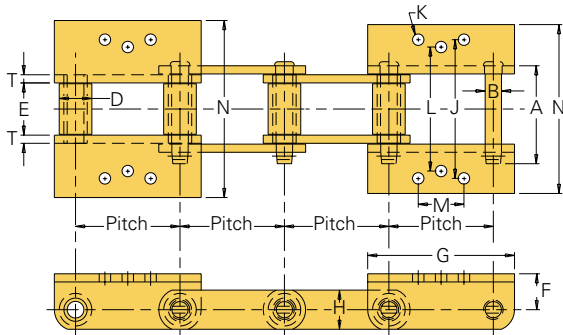

K-2 or K-44 Style Attachment

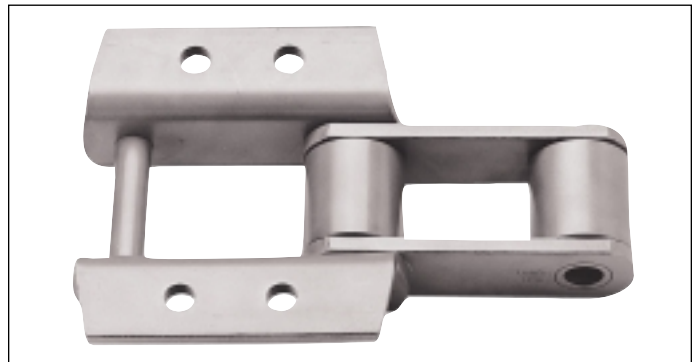
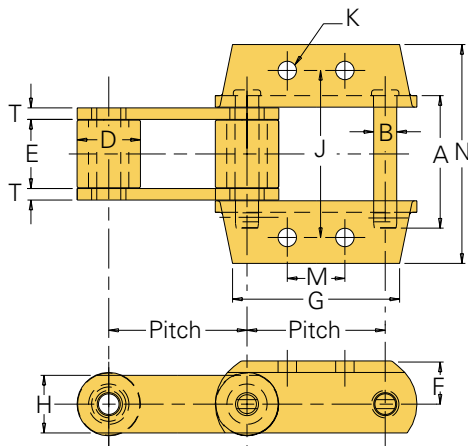

MM-1 Style Attachment

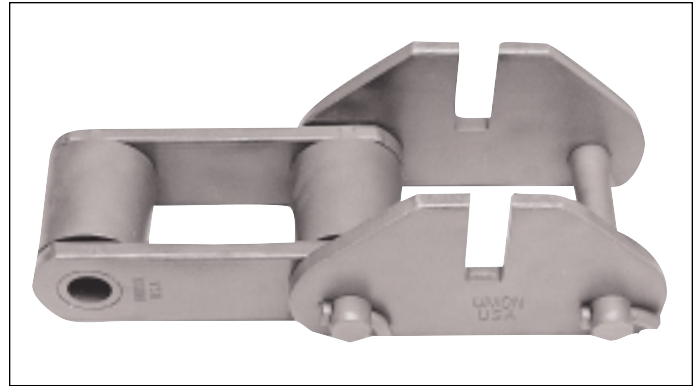
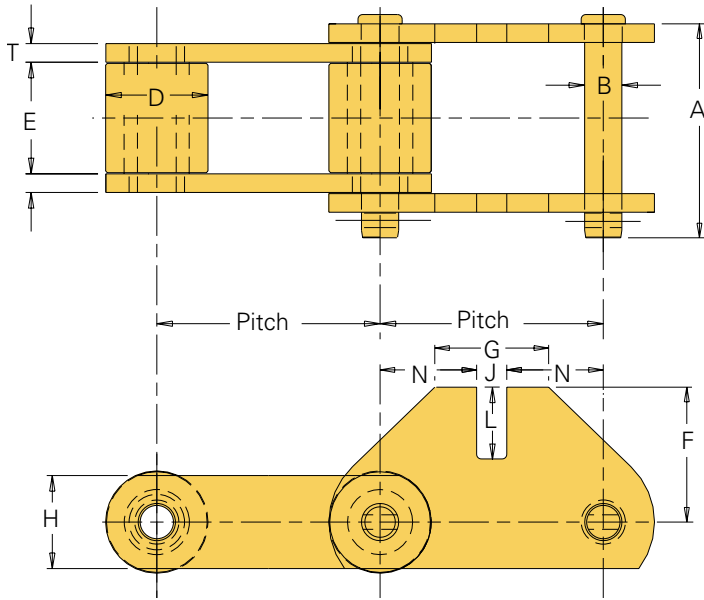

Incline Conveyor Chart

All dimensions are in inches unless otherwise indicated.

Dwg. No.	Description	Pitch	Pin		Inside Width E	Roller Dia. D	Sidebar		Attachment						Bolt Dia. K	Average Tensile Strength	Max. Work Load (lbs.)	Approx. Weight (lbs./ft.)
			A	B			H	T	F	G	M	N	J	L				
P-10024	2111/K-11 E/Pitch	6	3.69	0.75	1.56	1.88	2.00	0.38	1.63	3.00	—	6.79	4.75	—	0.69	83,000	5,900	12.1
P-10020	U-3945/K-3 E/3rd Pitch	4	3.75	0.63	2.00	1.25	1.50	0.31	1.38	5.63	1.75	6.50	5.31	4.75	0.44	44,000	5,740	9.8
P-10021	U-3952/K-2 *E/3rd Pitch	4	4.13	0.75	2.00	1.44	1.75	0.38	1.63	6.00	1.75	6.69	5.50	—	0.53	60,000	7,220	12.8
P-10022	3433 w/K-1/K-2 E/3rd (1.5" roller)	4	4.13	0.63	2.13	1.50	1.50	0.38	1.00	2.82	1.75	4.84	5.31	4.75	0.41	40,000	6,300	9.7
P-10023	U-3940/K-2 E/2nd Pitch	6	4.06	0.75	2.00	1.63	2.25	0.38	2.00	7.38	2.31	7.78	6.25	—	0.56	90,000	7,220	14.8
P-10025	856/K-24 E/2nd Pitch	6	5.75	1.00	3.00	—	2.50	0.50	1.88	7.25	2.50	9.50	7.25	—	0.75	145,000	14,000	16.5
P-10026	U-9856/K-44 E/2nd Pitch	6	5.75	1.00	3.00	2.75	2.50	0.50	1.88	7.25	2.50	9.52	7.25	—	0.81	140,000	14,000	30.0
P-10027	U-9856/MM-1 ¹ E/2nd Pitch	6	5.75	1.00	3.00	2.75	2.50	0.50	3.75	3.06	—	2.59	0.81	2.75	—	140,000	14,000	29.1

¹Verify attachment sidebar slot width and depth dimensions prior to ordering
* Square hole on attachment

Make In-Line Inspections Easy

Put machinery access at your fingertips. ONE-TOUCH INSPECTION DOOR® is a dust- and rain-tight inspection and service door for conveyors, as well as processing and handling equipment. These pre-fabricated units are in-stock and ready-to-go for easy installation at the job site. Once in place, ONE-TOUCH INSPECTION DOOR allows for quick and simple inspection without the need for special tools: just lift the lever! No bolts to loosen and no covers to misplace. One touch is all it takes...it's that simple. For more information, see the ONE-TOUCH INSPECTION DOOR description in Section C.

To locate compatible sprockets for your chain, refer to the Product Cross-Reference in Section D.

Note: Dimensions are subject to change. Contact Union Chain to obtain certified prints for design and construction.

ONE-TOUCH INSPECTION DOOR® is a registered trademark of Tsubaki Conveyor of America, Inc.

THE UNION SOLUTION

- High quality, tough chains
- Withstands impact loads
- Reliability
- Durability
- Strong, long-lasting