

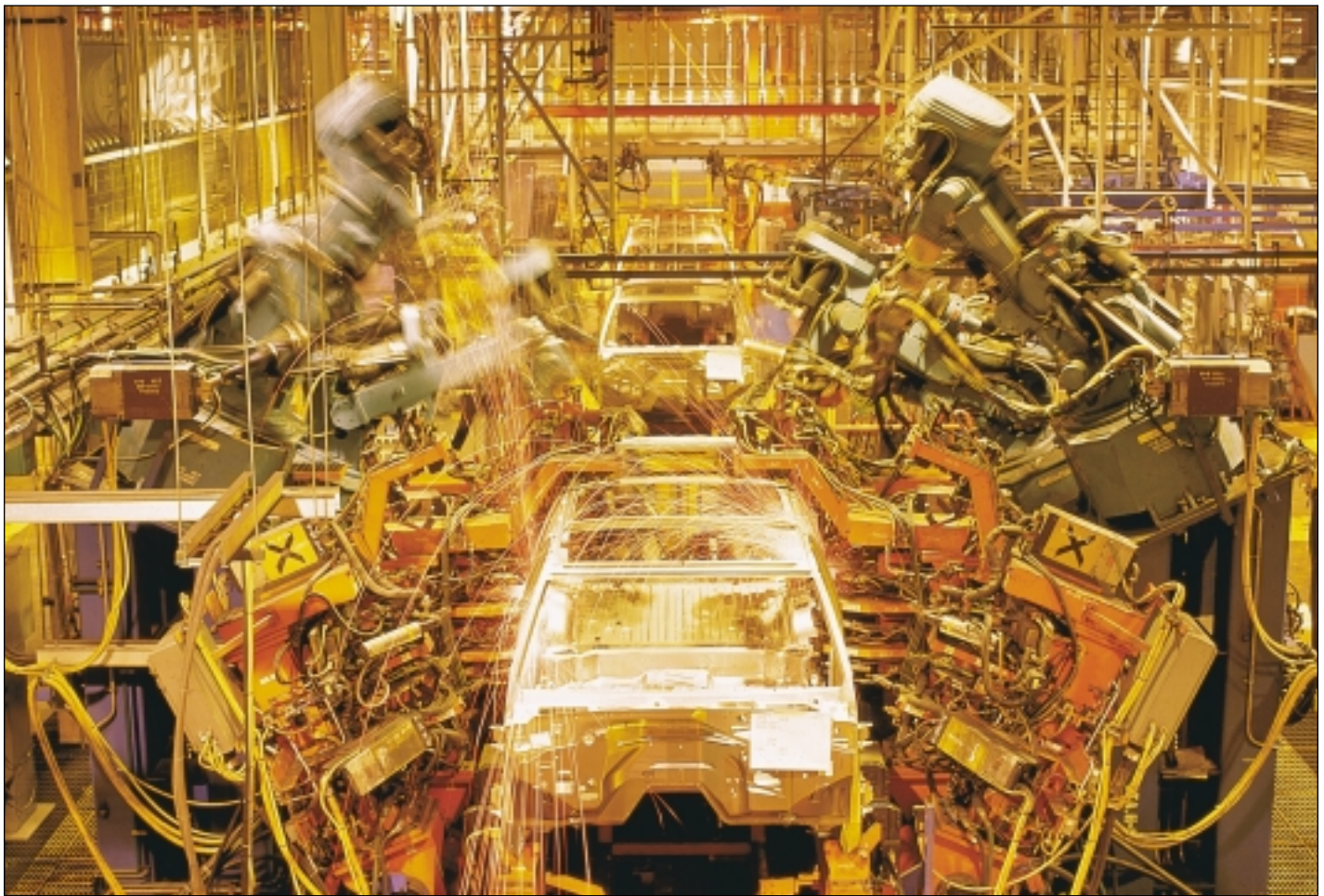

# Automotive Industry

The Union Chain Division of U.S. Tsubaki, Inc., is a vital partner of the auto industry. Our chains are found in plants throughout North America. Only Union Chain Division offers such a wide selection of chain sizes, types, and configurations. Many chains are in-stock and ready for immediate shipment. In addition, we can make chains to your exact specifications. Union delivers high added value and longer service life for your heavy-duty applications.



## High Sidebar Roller Conveyor Chain/ CC5 Chain

CC5 High Sidebar Roller Conveyor Chain is the most widely used conveyor chain in the auto industry, and no wonder:

- CC5 meets industry quality standards, which means better reliability for your application.
- CC5 rolls on any flat, firm surface, which means “instant conveying” for auto parts.
- CC5 can be customized, including welded-on flat tops, hex holes in sidebar for gravity roll conveyors, top rollers, and custom-specified attachments.

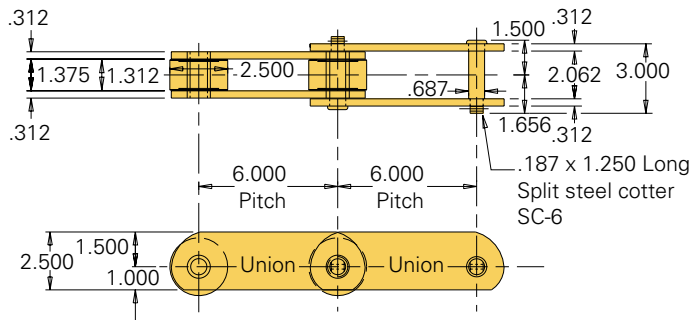

### CC5 Specifications

Standard Ultimate Strength	50,000 lbs.
Max. Allowable Working Load	4,800 lbs.
Weight per Foot	11 lbs.

## Flat Top and Gull Wing Chains

Double strand Flat Top Chain with outboard carrying rollers moves heavy loads with dependability. Top plate surfaces may be smooth, checkered, or nonskid. Chain pitch ranges from 4" to 24". Gull Wing Chain provides an alternative to Flat Top,

keeping the conveyed materials in line during movement. Either style can be made from a variety of materials and heat-treated to stand up to extreme conditions.

### Flat Top Chain

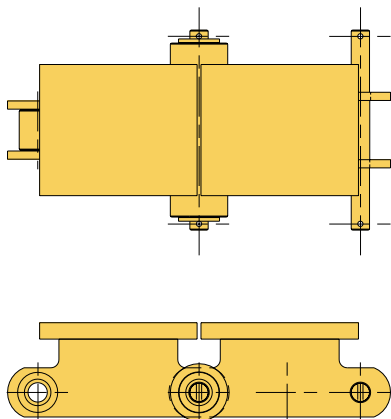

### Gull Wing Chain

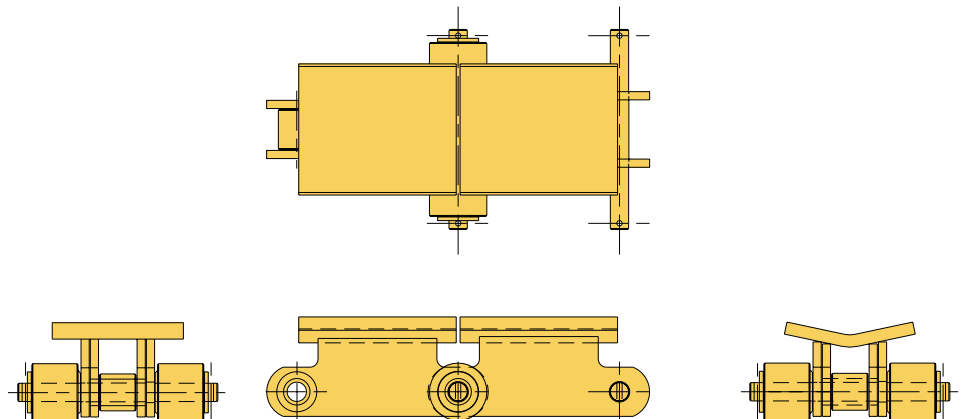

To locate compatible sprockets for your chain, refer to the Product Cross-Reference in Section D.

Note: Dimensions are subject to change. Contact Union Chain to obtain certified prints for design and construction.

## Drop Forged Rivetless Chains

Drop Forged Rivetless Chains from U.S. Tsubaki offer an optimum combination of chain strength and wear life. Quality heat-treated steel provides hardness where it matters to reduce line breaks. Precise pitch control ensures consistent, reliable performance. Power and free units, multi-lane operations, trolley conveyors, overhead handling systems — choose Union Drop Forged Rivetless Chain whenever dependable material handling is required.

## Drop Forged Rivetless Chain



## X-Style Drop Forged Rivetless Chain

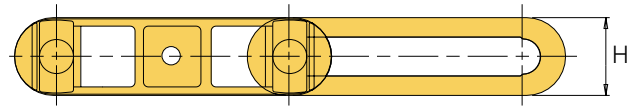
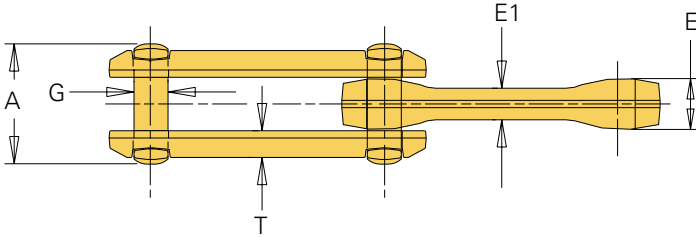

## Standard Drop Forged Rivetless Chain

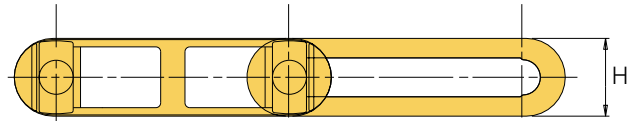
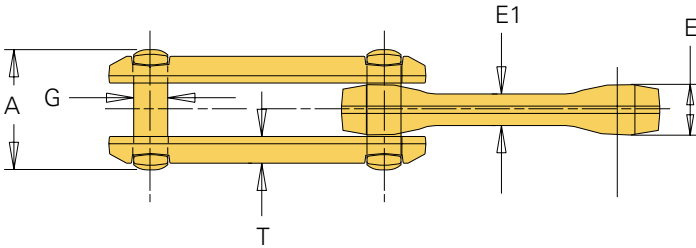

## Drop Forged Rivetless Chain

All dimensions are in inches unless otherwise indicated.

Chain Number	Pitch	Chain Width			Pin	Sidebars		Average Ultimate Strength (lbs.)		Maximum Work Load (lbs.)		Average Pitches (ft.)	Approx. Weight (lbs./ft.)
		Overall	Inside Width		Diameter	Thick.	Height	Alloy Heat Treated <sup>1</sup>	Heat Treated	Normal	Freq. Flex		
			A	E									
X-348 <sup>2</sup>	3.015	1.73	.75	.50	.50	.41	1.09		24,000	2,600	1,200	3.95	2.2
X-458 <sup>2</sup>	4.031	2.19	1.00	.63	.63	.47	1.38	60,000	48,000	4,000	1,900	2.98	3.2
X-678 <sup>2</sup>	6.031	3.03	1.28	.81	.88	.72	2.00	100,000	85,000	7,100	3,300	1.99	6.7
698	6.031	3.75	1.56	1.00	1.13	.56	2.56	150,000	130,000	10,800	5,200	1.99	11.4
998	9.031	3.75	1.56	1.00	1.13	.63	2.53	150,000	130,000	10,800	5,200	1.33	9.0

 Indicates this chain is normally stocked. All others are made-to-order.

<sup>1</sup>ANSI/SAE 8642

<sup>2</sup>The prefix "X" designates a design proportioned to flex transversely on a shorter radius. The outside bars are made with a mid-pitch panel that strengthens the sidebar and prevents material from falling through the link. X-Styles are used on overhead conveyors and other special applications. Attachments shown fit both Standard and X-Style Chain.

To locate compatible sprockets for your chain, refer to the Product Cross-Reference in Section D.

Note: Dimensions are subject to change. Contact Union Chain to obtain certified prints for design and construction.

**Extended Pin**

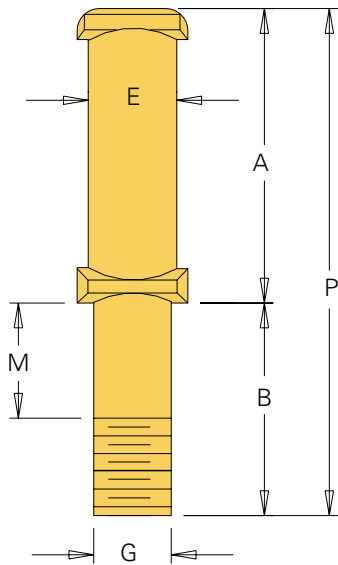

**S-22 Attachment**

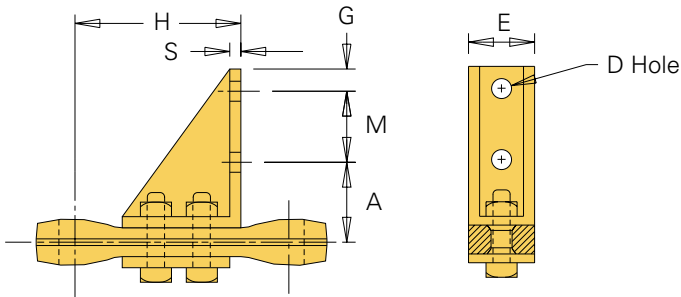

**Drop Forged Rivetless Chain Attachments**

All dimensions are in inches unless otherwise indicated.

Attachment Number	Chain Number	A	B	D	E	G	H	M	P	S	Approx. Chain Weight (lbs./ft.)
Extended Pin	X-458	2.25	1.13		.63	.50		.31	3.38		.3
	X-678	3.13	1.50		.88	.75		.19	4.63		1.6
	X-678	3.13	1.50		.88	.88		.19	4.63		1.6
	998	3.88	1.75		1.13	.75		.38	5.63		1.9
S-22 Attachment	X-458	2.25		.56	1.38	.63	3.18	2.00		.31	2.0
	X-678	2.88		.68	1.81	.88	4.75	2.25		.31	4.7

To locate compatible sprockets for your chain, refer to the Product Cross-Reference in Section D.

Note: Dimensions are subject to change. Contact Union Chain to obtain certified prints for design and construction.

## Higher Hardness Pin for "Ultra Wear Life" Performance

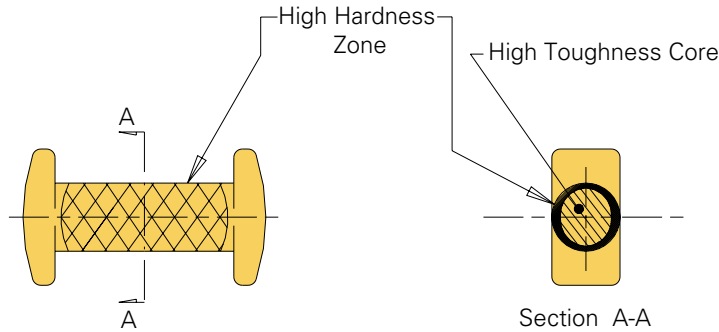

## UWL-Drop Forged Rivetless Chains

Ultra Wear Life Drop Forged Rivetless Chains are innovative products that extend wear life of rivetless chain 40 percent or more. This extraordinary performance is achieved with special steels and a special pin hardening process. That means significant savings of time and money, by reducing maintenance and changeout costs, decreasing downtime, and lowering repair bills.

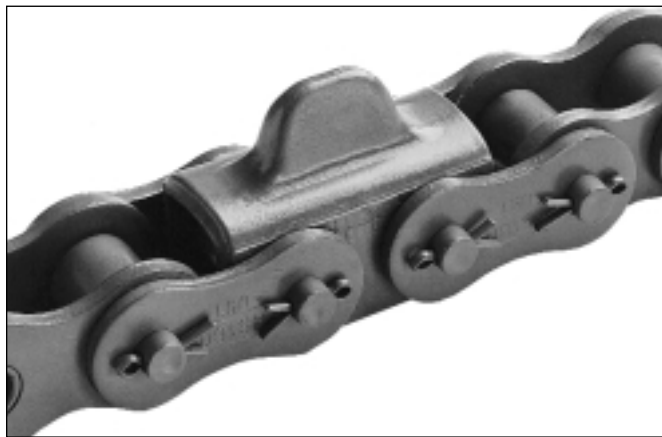

## Caterpillar Drive (Power) Chains

Caterpillar Drive Chains must deliver fatigue-free operation. Every part of Caterpillar Drive Chain from the Union Chain Division is top of the line. The roller chain is high-quality, with many drive dogs made of one-piece forged, induction-hardened steel. Special, made-to-order caterpillar chains are also available. The entire assembly is designed to operate flawlessly in combination with Drop Forged Rivetless Chain.

### Caterpillar Drive Dog

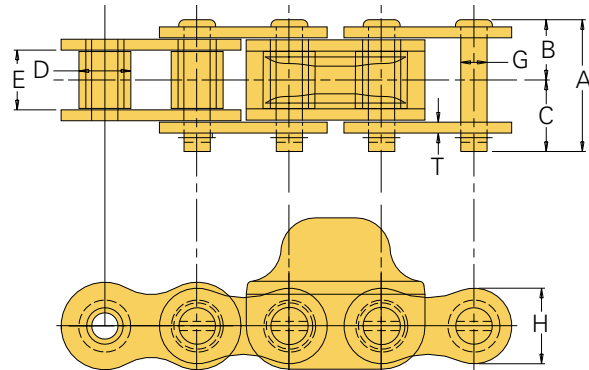

## Caterpillar Drive Chain

All dimensions are in inches unless otherwise indicated.

Chain Number	Pitch	Chain Width				Diameter		Sidebars		Driving Dog Pitch Spacing	Average Ultimate Strength (lbs.)	Approx. Weight (lbs./ft.)
		Overall	Pin Head to CL	Pin End to CL	Inside Width	Roller	Pin	Thick.	Height			
		A	B	C	E	D	G	T	H			
160/348	2.000	2.64	1.23	1.41	1.25	1.13	.56	.25	1.90	6	58,000	8.3
160/458	2.000	2.64	1.23	1.41	1.25	1.13	.56	.25	1.90	4 or 6	58,000	8.3 or 10.0
160/678	2.000	2.64	1.23	1.41	1.25	1.13	.56	.25	1.90	6	58,000	9.8

 Indicates this chain is normally stocked. All others are made-to-order.

To locate compatible sprockets for your chain, refer to the Product Cross-Reference in Section D.

Note: Dimensions are subject to change. Contact Union Chain to obtain certified prints for design and construction.



## Top Roller Chains

Build a long-lasting accumulating conveyor for heavy loads. Top Roller Chain is designed for engine production lines or any time you want to temporarily stop or accumulate products or materials without halting the entire line. With Top Roller Chain, you can stop the movement of conveyed products while the line continues to roll beneath. This affords manufacturing with buffer storage between production operations necessary to ensure consistent process throughput.

### 2.609" Pitch Top Roller Chain

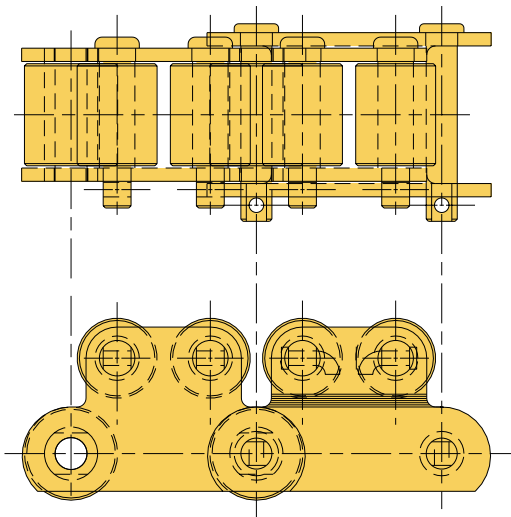

### 53R Top Roller Chain

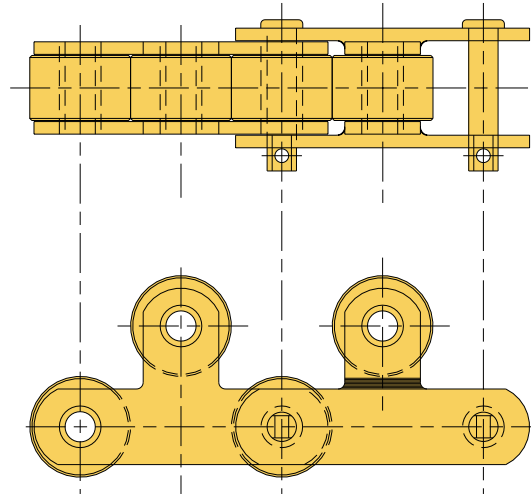

## Make In-Line Inspections Easy

Put machinery access at your fingertips. ONE-TOUCH INSPECTION DOOR® is a dust- and rain-tight inspection and service door for conveyors, as well as processing and handling equipment. These pre-fabricated units are in-stock and ready-to-go for easy installation at the job site. Once in place, ONE-TOUCH INSPECTION DOOR allows for quick and simple inspection without the need for special tools: just lift the lever! No bolts to loosen and no covers to misplace. One touch is all it takes...it's that simple. For more information, see the ONE-TOUCH INSPECTION DOOR description in Section C.

## THE UNION SOLUTION

- **Strong, long-lasting chain**
- **Quality that exceeds industry standards**
- **Variety of sizes and treatments**
- **Custom-specified constructions**
- **Precise pitch control**
- **Smooth bearing areas**