

# Water Treatment



**The Union Chain Division of U.S. Tsubaki Inc., offers a variety of drive and conveyor chains for use in water treatment applications. Many industrial plants and power stations draw water from nearby lakes, rivers, or bays for use in process and cooling applications and to feed boilers. Traveling water and bar screens prevent the intake of fish, rocks, debris, and suspended solids that could damage equipment or foul water circulation systems. Both types of screens use special chains that must be replaced periodically because of corrosion and wear.**

Industries commonly screening inlet waters include:

- Power generating plants (coal, petroleum, nuclear)
- Pulp and paper mills (also removing wastes from in-plant streams)
- Steel mills
- Chemical and processing plants
- Refineries
- Food processors
- Any plant operating a large power boiler to produce steam

## Select Union Chains

Union Traveling Water and Bar Screens are specially designed to stand up to this corrosive environment. Pins and bushings are through hardened for extended wear life. Rollers are constructed of cast iron or through hardened stainless steel and have a special synthetic resin bushing for smooth operation. The resin bushings require no lubrication, saving you time and money.

To add even more protection, Union Water Treatment Chains are double-treated for extra corrosion resistance—first with an adhesive sealant in the pin, bushing and link plate press-fit areas, and then with an anti-corrosion, rust-prevention coating. That means strong, long-lasting chain for your screening environment.

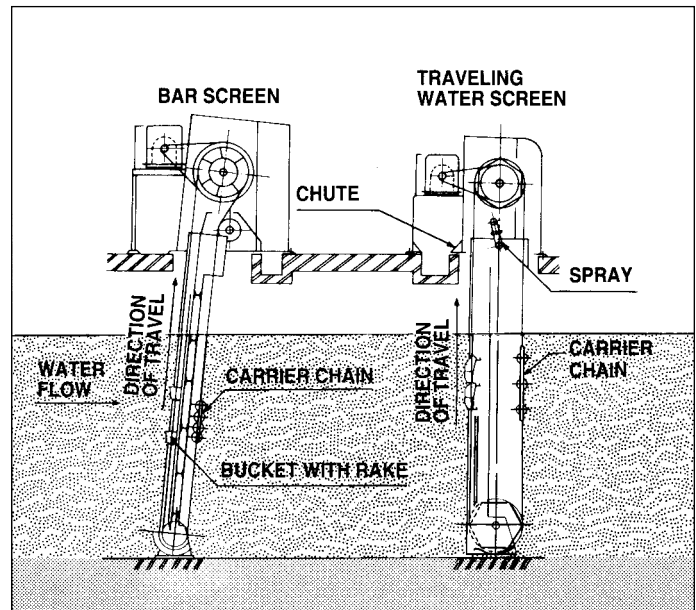

## Factors to Consider

**Kind of water.** Fresh water has a different chemistry than salt or brackish water and has a different impact on chain. Several different types of materials are used, including heat-treatable, stainless steels, alloy steels, and cast iron rollers. Choose the construction that is right for your application. If you have any questions, contact Union Engineering.

**Types of water screen chain.** There are three main types of water screen carrier chain. Union produces all three with either 3/8"- or 1/2"-thick sidebars. Pitch is usually 24", but each type has distinctive characteristics.

**Styles of bar screen chain.** 700 series, 6-inch pitch chains are widely used. Sidebars are usually 5/16" for standard and 3/8" for heavy-duty applications. Other chain series are also available.

## Style A

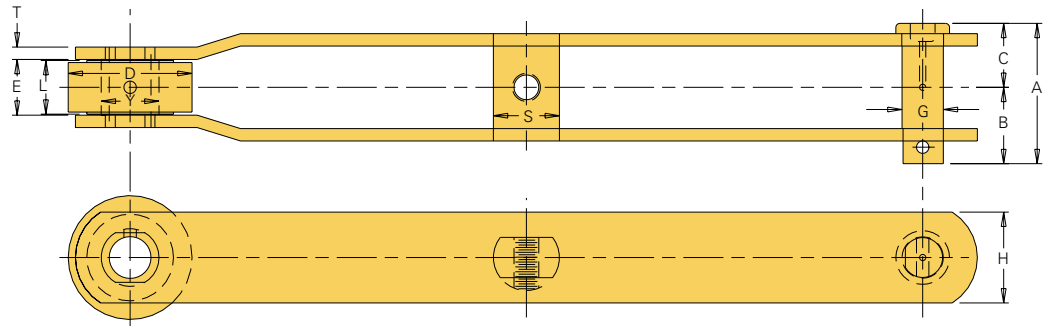

## Traveling Water Screen Chains

All dimensions are in inches unless otherwise indicated.

	Pitch	Width				Roller		Pin	Sidebar		Bushing	Bushing Attach.	Approx. Weight (lbs./ft.)
		Overall	Pin Head to CL	Pin End to CL	Inside	Diameter	Length	Diameter	Height	Thick.	Diameter	Diameter	
		A	C	B	E	D	L	G	H	T	Y	S	
Style A	24.000	4.25	1.94	2.31	1.69	3.75	1.63	1.25	2.75	.38	1.75	2.00	12.3
	24.000	4.75	2.19	2.19	1.69	3.75	1.63	1.25	2.75	.50	1.75	1.94	15.1

Note: Dimensions shown are nominal. Obtain certified prints for design and construction.

## Style B

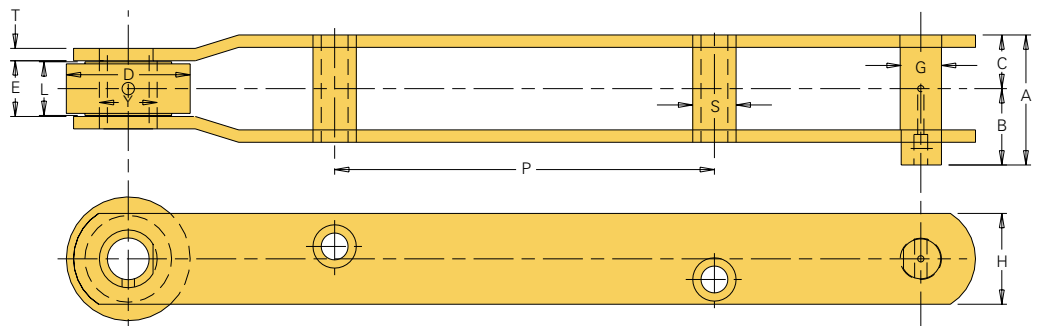

## Traveling Water Screen Chains

	Pitch	Width				Roller		Pin	Sidebar		Bushing	Bushing Attach.	Approx. Weight (lbs./ft.)
		Overall	Pin Head to CL	Pin End to CL	Inside	Dia.	Length	Dia.	Height	Thick.	Dia.	Dia.	
		A	C	B	E	D	L	G	H	T	Y	S	P
Style B	24.000	3.63	1.56	2.06	1.56	4.00	1.50	1.21	3.00	.38	1.75	1.31	11.50
	24.000	4.13	1.81	2.31	1.56	4.00	1.50	1.21	3.00	.50	1.75	1.31	11.50

Note: Dimensions shown are nominal. Obtain certified prints for design and construction.

To locate compatible sprockets for your chain, refer to the Product Cross-Reference in Section D.

Note: Dimensions are subject to change. Contact Union Chain to obtain certified prints for design and construction.

**Style C**

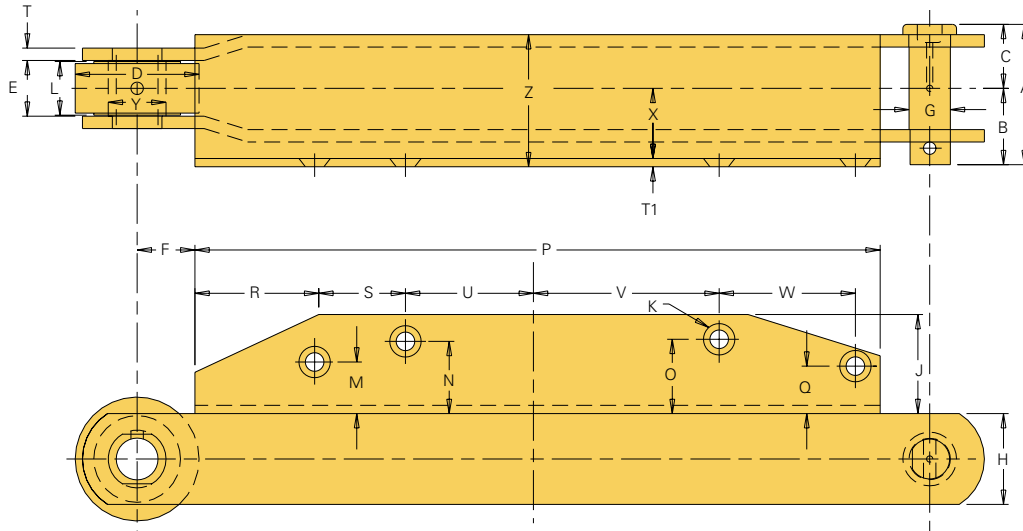

**Traveling Water Screen Chains**

All dimensions are in inches unless otherwise indicated.

	Pitch	Width				Roller		Pin	Sidebar		Bushing	Bushing Attachment														Approx. Weight (lbs./ft.)		
		Over-all	Pin Hd. to CL	Pin End to CL	In-side	Dia.	Lgth.	Dia.	Hgt.	Th.	Dia.	P	T1	J	M	N	O	Q	R	S	U	V	W	F	X		Z	K
		A	C	B	E	D	L	G	H	T	Y	P	T1	J	M	N	O	Q	R	S	U	V	W	F	X	Z	K	
Style	24.000	4.19	1.89	2.31	1.69	3.75	1.63	1.25	2.75	.38	1.75	20.75	.25	3.00	1.56	2.19	2.25	1.44	5.38	2.75	3.88	5.63	4.13	1.75	2.38	4.00	.53	15.8
C	24.000	4.75	2.19	2.56	1.69	3.75	1.63	1.25	2.75	.50	1.75	20.75	.25	3.00	1.56	2.19	2.25	1.44	5.38	2.75	3.88	5.63	4.13	1.75	2.63	5.00	.53	18.6

Note: Dimensions shown are nominal. Obtain certified prints for design and construction.

To locate compatible sprockets for your chain, refer to the Product Cross-Reference in Section D.

Note: Dimensions are subject to change. Contact Union Chain to obtain certified prints for design and construction.

## EPC-78 Chain

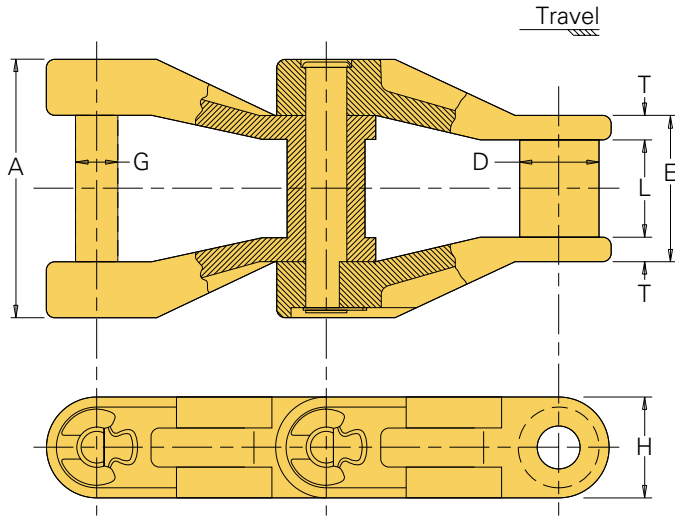

## WH-78 and 488 Chains

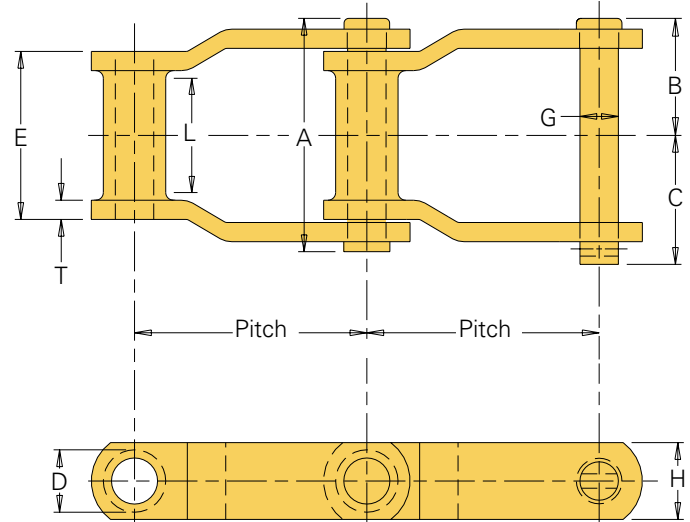

## US-882 Chain

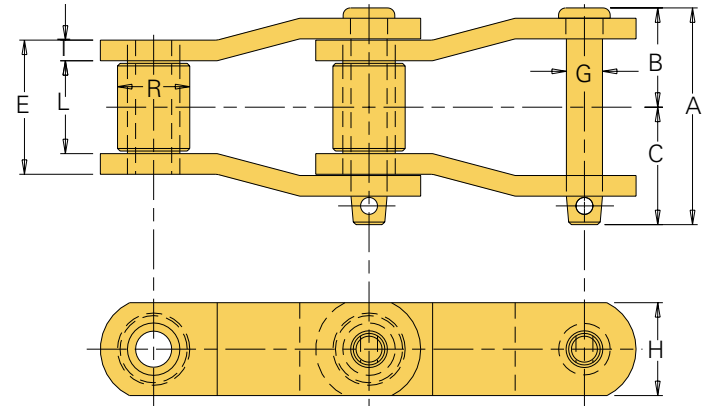

## Drive Chains (Rectangular Settling Tanks)

All dimensions are in inches unless otherwise indicated.

Chain No.	Pitch	Chain Width				Roller Dia.	Barrel Dia.	Pin Dia.	Sidebar			Avg. Ult. Stgth. (lbs.)	Max. Work Load (lbs.)	Approx. Weight (lbs./ft.)
		Overall	Pin Head to Center-line	Pin End to Center-line	Length of Bearing				Th.	Height	All Parts Heat Treated			
		A	B	C	E	R	D	L	G	T	H			
EPC-78	2.609	2.93			1.63		.88	1.09	.45	.27	1.13			1.5
WH-78	2.609	3.00	1.44	1.56	2.00		.88	1.13	.50	.25	1.13	33,000	3,500	4.0
488	2.609	2.75	1.31	1.44	1.63		.88	.94	.44	.25	.94	13,750	2,130	2.9
US-882	2.609	2.69	1.25	1.44	1.63	.88		1.13	.44	.25	1.13	26,000	2,500	3.6

Note: US-1030 and WH-82 are also commonly used.

To locate compatible sprockets for your chain, refer to the Product Cross-Reference in Section D.

Note: Dimensions are subject to change. Contact Union Chain to obtain certified prints for design and construction.

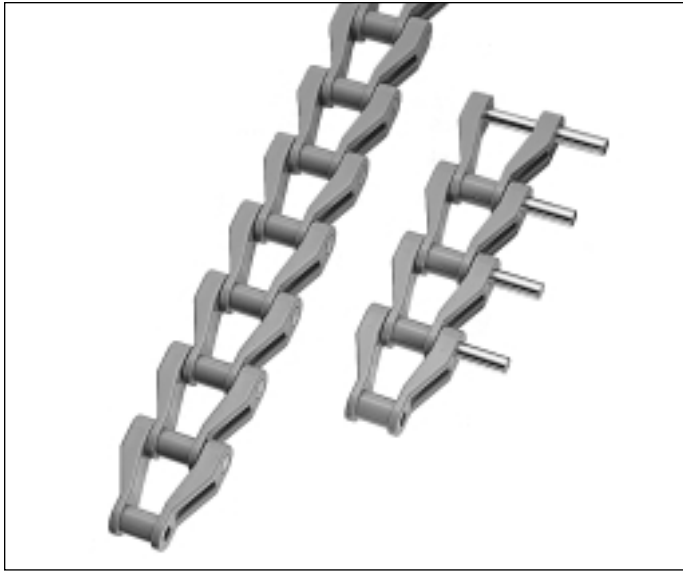

**EPC-78 Allowable Load and Speed**

Chain Speed (ft./min.)	Number of Sprocket Teeth			
	6	8	10	12
33	1,348	1,348	1,348	1,348
44	1,348	1,348	1,348	1,348
66	1,348	1,348	1,348	1,348
82	1,057	1,348	1,348	1,348
98	804	1,233	1,348	1,348

For higher chain speeds than shown above, please consult with Union Engineering.

**WH-720S and WH-720SH Chains**

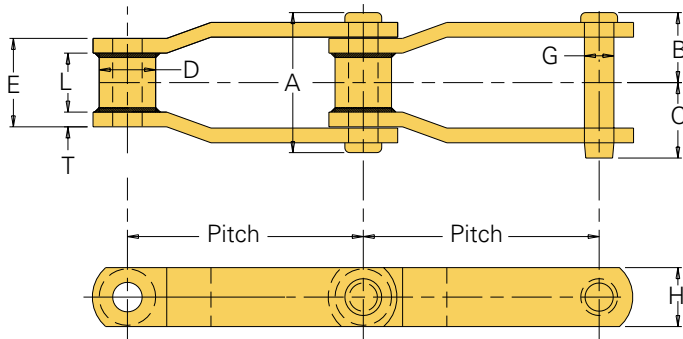

**Conveyor Chains (Rectangular Settling Tanks)**

All dimensions are in inches unless otherwise indicated.

Chain Number	Pitch	Chain Width				Barrel		Pin	Sidebars			Average Ultimate Strength (lbs.)	Max. Work Load (lbs.)	Approx. Weight (lbs./ft.)
		Overall	Pin Head to Center-line	Pin End to Center-line	Length of Bearing	D	L	Dia.	Thick.	Height	All Parts Heat Treated	All Parts Heat Treated		
											A	B	C	
WH-720S	6.000	3.94	1.81	2.13	2.13	1.44	1.50	.75	.31	1.50	60,000	5,570	5.2	
WH-720SH	6.000	4.06	1.88	2.19	2.25	1.44	1.50	.75	.38	1.50	60,000	5,900	6.1	

To locate compatible sprockets for your chain, refer to the Product Cross-Reference in Section D.

Note: Dimensions are subject to change. Contact Union Chain to obtain certified prints for design and construction.

**AM-116 Attachment**

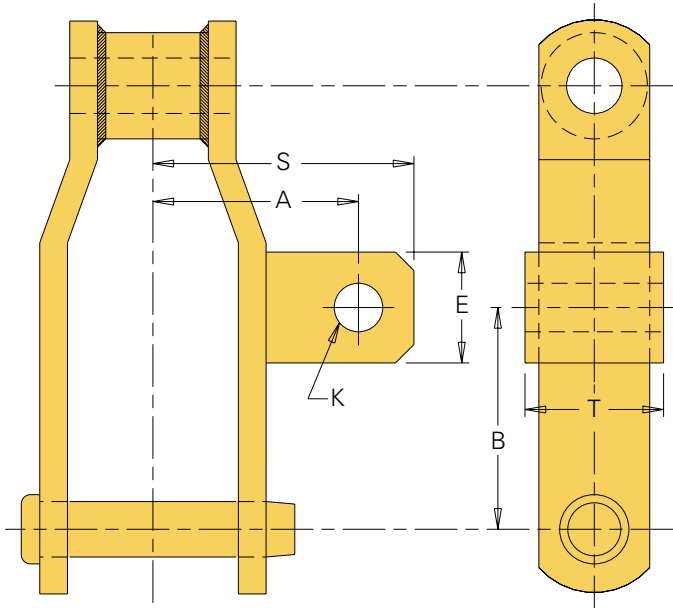

**AD-474 Attachment**

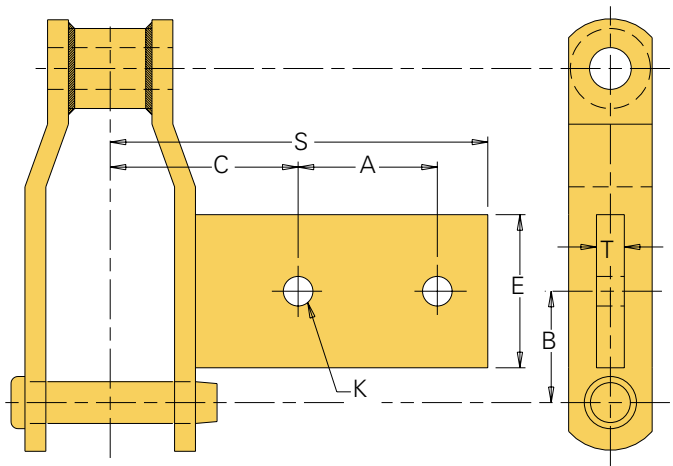

**A-42 Attachment**

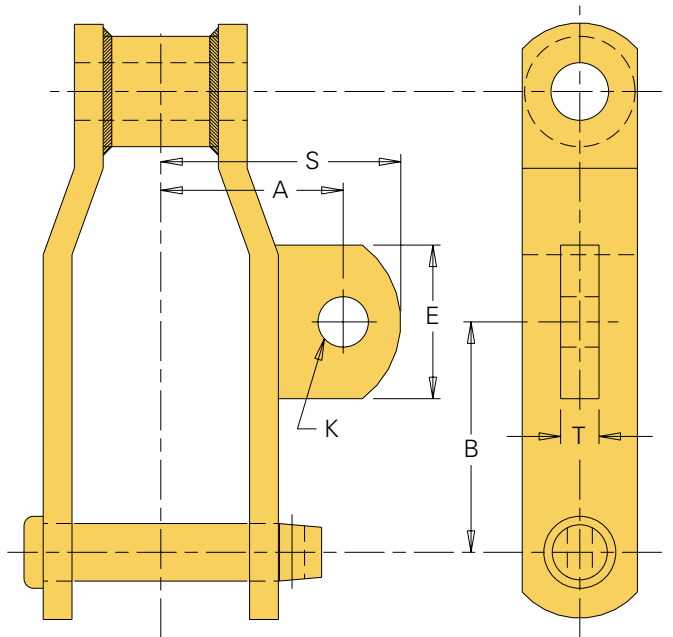

**K-2 Attachment**

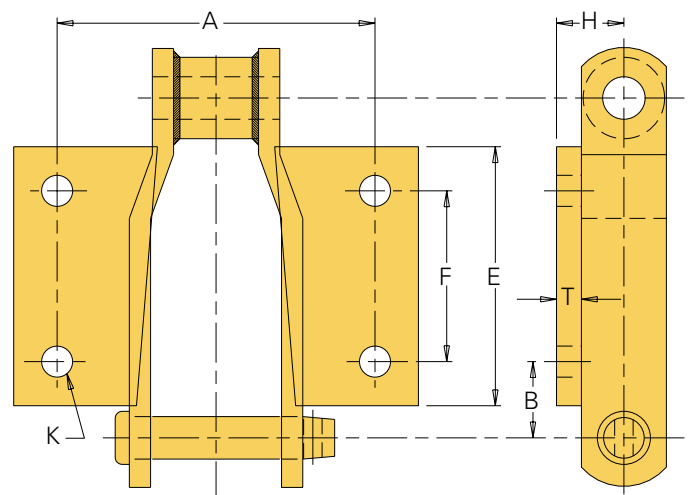

To locate compatible sprockets for your chain, refer to the Product Cross-Reference in Section D.

Note: Dimensions are subject to change. Contact Union Chain to obtain certified prints for design and construction.

**F-2 Attachment**

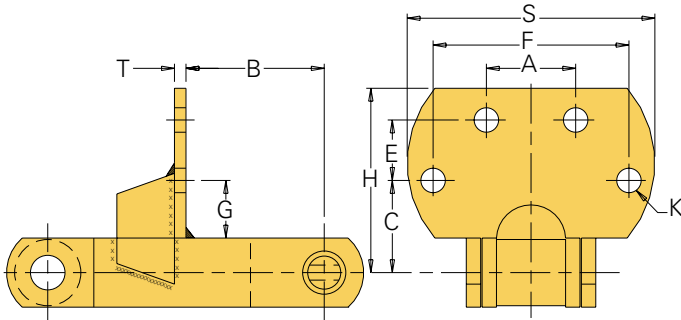

**F-22-6 and F-22-8 Attachments**

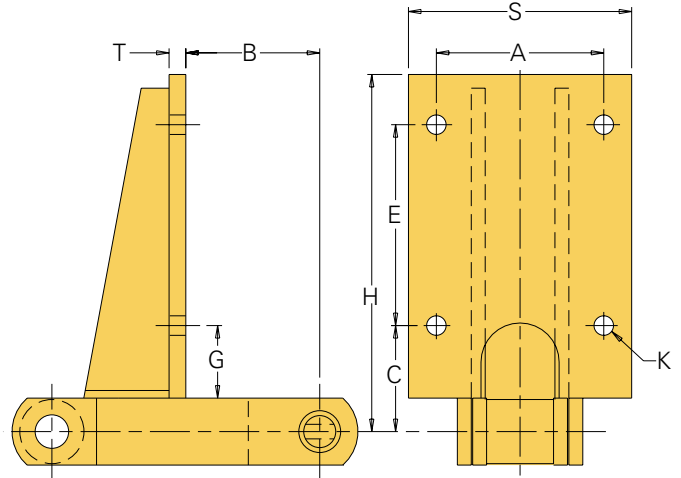

**Conveyor Chain Attachments**

All dimensions are in inches unless otherwise indicated.

Attach. Number	A	B	C	E	F	G	Maximum H	Maximum S	T	Bolt Diameter K
AM-116	2.78	3.00		1.50				3.56	1.88	.63
AD-474	2.50	2.00	3.38	2.75				6.81	.50	.50
A-42	2.38	3.00		2.00				3.19	.50	.63
K-2	6.00	1.69		4.14	2.62		.94		.31	.50
F-2	1.94	3.00	2.00	1.31	4.25	1.06	3.94	5.44	.25	.38
F-22-6	3.75	3.00	2.38	2.63		1.47	6.14	5.64	.25	.38
F-22-8	3.75	3.00	2.38	4.50		1.47	8.14	5.64	.25	.38

**Make In-Line Inspections Easy**

Put machinery access at your fingertips. ONE-TOUCH INSPECTION DOOR® is a dust- and rain-tight inspection and service door for conveyors, as well as processing and handling equipment. These pre-fabricated units are in-stock and ready-to-go for easy installation at the job site. Once in place, ONE-TOUCH INSPECTION DOOR allows for quick and simple inspection without the need for special tools: just lift the lever! No bolts to loosen and no covers to misplace. One touch is all it takes...it's that simple. For more information, see the ONE-TOUCH INSPECTION DOOR description in Section C.

**THE UNION SOLUTION**

- **High strength**
- **Exceptional wear resistance**
- **Superior anti-corrosion properties**
- **Durability**
- **Reliability**