



Double Flex Chains

Double Flex Chain rotates on two planes, making it an ideal choice for a wide variety of applications. The pin bearing surfaces and selected sliding surfaces are induction hardened for extended wear life.

The Double Flex Chain offers a large sliding area to decrease shear on the chain and the sliding surface because design allows maximum flexibility for both horizontal and vertical movement.

This versatility allows compact layouts and economical cost. The mechanically designed cupped shape of the outer link plates of DF-3500 and DF-3910 eases side flex movement and protects rivet ends. This feature also prevents pin wear at the ends. DF-3498 offers flexibility with straight outer link plates.

The drawings shown are examples of just a few double flex chain styles. Many additional styles and configurations are available on a made-to-order basis. Sprockets are also available — split, solid, or bronze bushed.

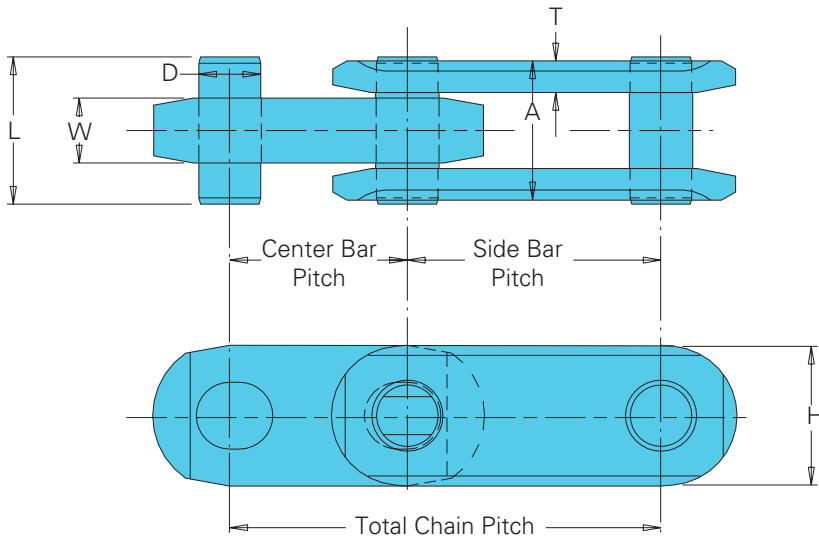

Table 1 — Double Flex Chain

Ratio of Chain Speed (FPM) to Conveyor Length (ft.)	Maximum Allowable Working Load (lbs.)
0.1–0.6	4,000
1.0	3,400
1.5	2,900
2.0	2,600
2.5	2,300
3.0	2,100
3.0–15.0	2,100

For ratios less than 0.1 or more than 15.0, consult Union for suggested working load.

DF-3498



DF-3500 and DF-3910

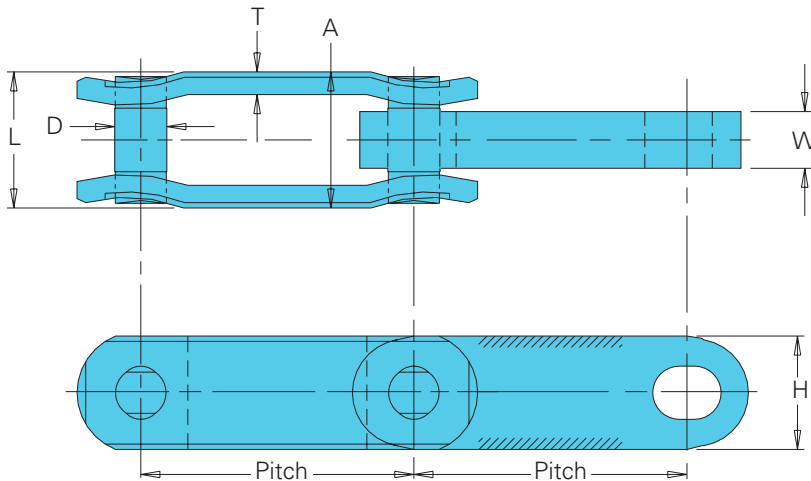

Note: Hatching shows induction hardened area.

Double Flex Chain

All dimensions are in inches unless otherwise indicated.

Chain Number	Pitch	Chain Width		Link Plate		Pin		Minimum Flex Radius	Average Tensile Stgth.(lbs.)	Maximum Allowable Work Load ¹ (lbs.)	Approx. Weight (lbs./ft.)
		Overall	Inside Link								
		A	W	T	H	D	L				
DF-3498	1.750 2.500	1.45	.64	.31	1.40	.63	1.45	18.00	50,000	4,000	3.9
DF-3500	2.500 3.000	1.50	.63	.25	1.25	.57	1.46	20.00	48,000	4,000	3.3
DF-3910	3.000 3.000	1.50	.63	.25	1.25	.57	1.46	22.00	48,000	4,000	3.3

Indicates this chain is normally stocked. All others are made-to-order.

¹Working load for speed length ratio V/S up to 0.6., where V = chain speed (ft./min.) and S = conveyor length (ft.). For other speed length ratios, see Table 1.

To locate compatible sprockets for your chain, refer to the Product Cross-Reference in Section D.

Note: Dimensions are subject to change. Contact Union Chain to obtain certified prints for design and construction.