

# Flow Conveyor Chains

This chain is based on standard conveyor chain. Various types of standardized attachments are available for suitability with the conveyed material. The materials of the standard chain are identical to the DT (Basic) Series or AT Series, but other series are also available upon request.

Attachment	Application
L	Conveying grain or cement
KL	Conveying adhesive powder
B (round)	Conveying powdered material like flour or cements at higher conveying efficiency than L attachment
B (square)	Conveying massive, powdered, or adhesive materials that are hard to convey with B (round) attachment
U <sub>2</sub> V (round)	A larger conveyor than L, KL, B, or for an upgrade
U <sub>2</sub> V (square)	Conveying massive, powdered, or adhesive materials that are hard to convey with U <sub>2</sub> V (round)

## RF Conveyor Chain for FC Type Horizontal Flow Conveyor

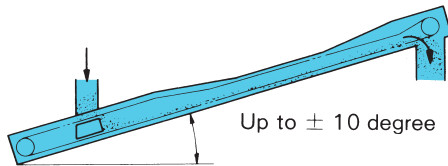

### "L" Attachment

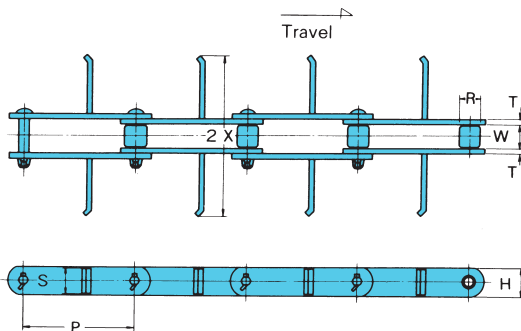

### "B" (square) and "B" (round) Attachments

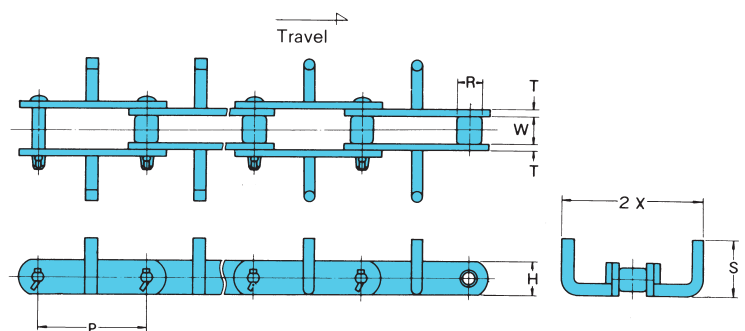

**“KL” Attachment**

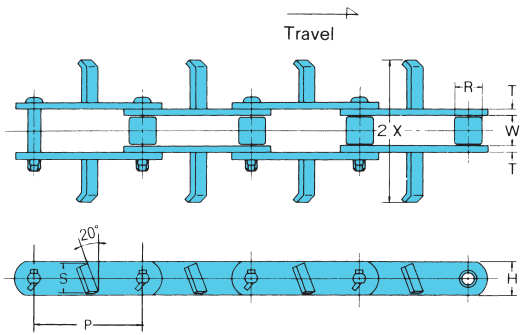

**“U2V” (square) and “U2V” (round) Attachments**

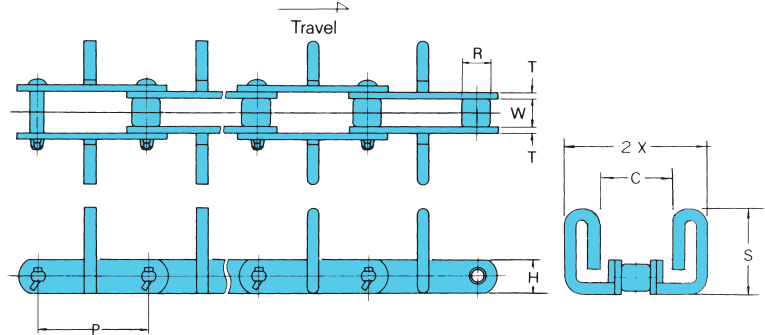

**RF Flow Conveyor Specifications**

All dimensions are in inches unless otherwise indicated.

Chain Number	Former Chain Number	Flow Model Number	Pitch	Roller Diameter	Width Between Roller Link Plates	Link Plate		Attachment
						H	T	
			P	R	W	H	T	2X
RF10125-M	F6, FA6	FC200	4.921	1.252	1.181	1.500	.248	7.283
RF10150-M		FC270	5.905	1.252	1.181	1.500	.248	9.843
RF6205-M		FC270	6.000	1.500	1.461	1.752	.311	9.843
RF12200-M		FC350	7.874	1.500	1.461	1.752	.311	12.992
RF17200-M		FC350	7.874	1.752	2.024	2.000	.374	12.992
RF17250-M	F8, FA8	FC450	9.842	1.752	2.024	2.000	.374	16.929
RF26200-M		FC410	7.874	2.000	2.252	2.500	.374	15.354
RF26250-N		FC450	9.842	2.000	2.252	2.500	.374	16.929
RF26300-N	F12	FC580	11.811	2.000	2.252	2.500	.374	15.354
RF36300-M		FC580	11.811	2.252	2.626	3.000	.500	22.047
RF36300-N		FA12	FC580	11.811	2.252	2.626	3.000	.500

**RF Flow Conveyor Attachment Specifications**

Chain Number	L Attachment		KL Attachment		B Attachment		U2V Attachment			Avg. Tensile Stgth.	
	S	Approx. Weight (lbs./ft.)	S	Approx. Weight (lbs./ft.)	S	Approx. Weight (lbs./ft.)	S	C	Approx. Weight (lbs./ft.)	DT (Basic) Series (lbs.)	AT Series (lbs.)
RF10125-M	1.339	5.44	1.339	5.44	3.150	5.98	4.528	3.346	6.92	25,300	50,600
RF10150-M	1.339	5.44	1.339	5.44	3.937	6.59	5.512	4.134	8.53	25,300	50,600
RF6205-M	1.575	8.06	1.575	8.06	3.937	8.33	5.512	4.134	10.48	41,800	62,700
RF12200-M	1.575	8.06	1.575	8.06	4.921	9.14	7.283	5.118	12.36	41,800	62,700
RF17200-M	1.811	11.42	1.811	11.42	4.921	11.76	7.283	5.118	14.99	55,000	86,900
RF17250-M	1.811	10.95	1.811	10.95	6.299	12.63	9.055	5.315	15.93	55,000	86,900
RF26200-M	2.283	18.81	2.283	18.81	5.906	16.80	9.173	3.937	22.85	70,400	116,600
RF26250-N	2.283	14.11	2.283	14.11	6.299	15.05	9.055	5.315	19.82	67,100	126,500
RF26300-N	2.283	15.46	2.283	15.46	7.874	18.14	11.417	6.299	28.22	67,100	126,500
RF36300-M	2.756	22.85	2.756	22.85	7.874	24.33	11.417	6.299	33.94	106,700	152,900
RF36300-N	2.756	22.85	2.756	22.85	7.874	24.33	11.417	6.299	33.94	—	194,700

To locate compatible sprockets for your chain, refer to the Product Cross-Reference in Section D.

Note: Dimensions are subject to change. Contact Union Chain to obtain certified prints for design and construction.

## RF Conveyor Chain for LCType Inclined Flow Conveyor

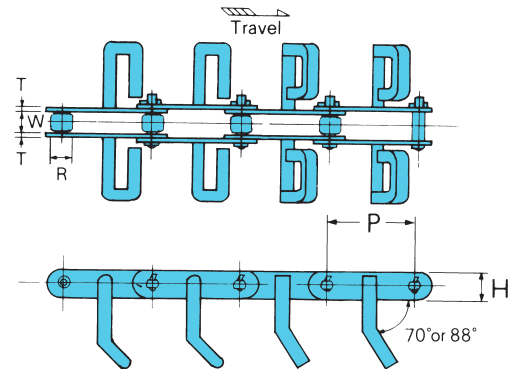
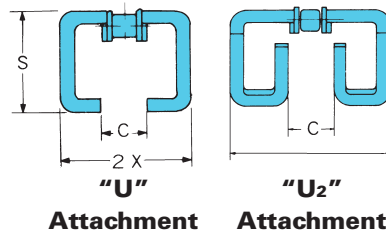
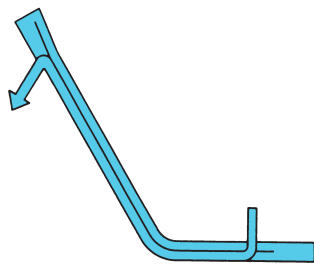

Attachment	Application	Attachment	Application
U (round steel bar)	for conveying general powdered materials	U <sub>2</sub> (round steel bar)	for conveying material at higher efficiency than U (round)
U (square steel bar)	for conveying massive, powdered, or adhesive materials	U <sub>2</sub> (square steel bar)	for conveying material at higher efficiency than U (square)

### Specifications

All dimensions are in inches unless otherwise indicated.

Chain Number	Former Chain No.	Flow Model No.	Pitch	Roller Dia.	Width Between Roller Link Plates	Link Plate		"U" Attachment			"U <sub>2</sub> " Attachment		Avg. Tensile Stgth.			
						H	T	2X	S	C	Approx. Wgt. (lbs./ft.)	S	C	Approx. Wgt. (lbs./ft.)	"DT" Series (lbs.)	"AT" Series (lbs.)
			P	R	W	H	T	2X	S	C		S	C			
RF450W-M	F4,FW4	$\frac{1}{8}$ " 160	4.000	1.000	1.063	1.252	.248	5.709	4.331	1.969	5.78	4.331	1.969	6.45	24,200	31,900
RF10125-M		$\frac{1}{8}$ " 240	4.921	1.252	1.811	1.500	.248	8.858	5.512	2.559	8.74	5.512	2.559	9.95	25,300	50,600
RF6205-M	F6,FA6	$\frac{1}{8}$ " 320	6.000	1.500	1.461	1.752	.311	11.811	6.890	3.150	13.10	6.890	3.150	15.05	42,000	62,700
RF17200-M		$\frac{1}{8}$ " 410	7.874	1.752	2.024	2.000	.374	15.354	8.661	3.937	17.81	8.661	3.937	20.36	55,000	86,900
RF26200-M	F8,FA8	$\frac{1}{8}$ " 410	7.874	2.000	2.252	2.500	.374	15.354	8.661	3.937	20.50	8.611	3.937	22.78	70,400	116,600
RF26200-N	F8,FA8	$\frac{1}{8}$ " 410	7.874	2.000	2.252	2.500	.374	15.354	8.661	3.937	20.50	8.661	3.937	22.78	67,100	126,500
RF36300-M	F12	$\frac{1}{8}$ " 500	11.811	2.252	2.626	3.000	.500	18.898	10.236	4.724	28.56	10.236	4.724	31.58	106,700	—
RF36300-M	F12	$\frac{1}{8}$ " 600	11.811	2.252	2.626	3.000	.500	22.835	12.008	5.512	31.72	12.008	5.512	35.62	106,700	—
RF36300-N	FA12	$\frac{1}{8}$ " 500	11.811	2.252	2.626	3.000	.500	18.898	10.236	4.724	28.56	10.236	4.724	31.58	—	194,700
RF36300-N	FA12	$\frac{1}{8}$ " 600	11.811	2.252	2.626	3.000	.500	22.835	12.008	5.512	31.72	12.008	5.512	35.62	—	194,700

To locate compatible sprockets for your chain, refer to the Product Cross-Reference in Section D.

Note: Dimensions are subject to change. Contact Union Chain to obtain certified prints for design and construction.

## RF Conveyor Chain for FK Type Flow Conveyor for Grain

This chain is specially designed for horizontal flow conveyors (upgrade or downgrade 10°) that handle grain. The sweeping board prevents material on the rail from being crushed and the cleaner sweeps the material off the case.

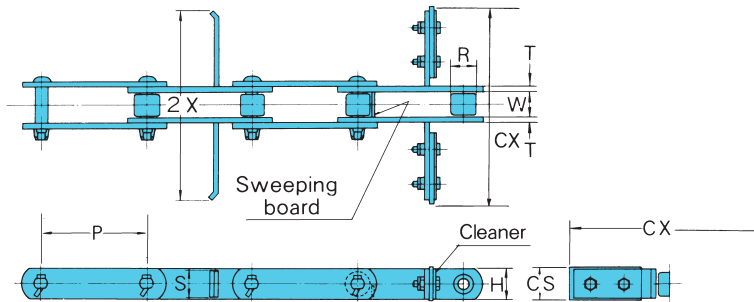

### Specifications

All dimensions are in inches unless otherwise indicated.

Chain Number	Flow Model No.	Pitch	Roller Dia.	Width Between Roller Link Plates	Link Plate		Attachment		Cleaner		Approx. Weight (lbs./ft.)	Average Tensile Strength (lbs./ft.)
					H	T	2X	S	CX	CS		
RF03075-S	FK110	2.952	.626	.634	.866	.126	3.740	.787	4.134	1.102	1.41	6,600
RF430-S	FK150	4.000	.791	.890	1.000	.189	5.315	.866	5.709	1.260	2.28	12,100
RF450-S	FK150	4.000	.874	1.063	1.126	.248	5.315	.984	5.709	1.339	3.36	17,600
RF08125-S	FK200	4.921	.874	1.063	1.126	.248	7.283	.984	7.677	1.339	3.36	17,600
RF10125-S	FK200	4.921	1.142	1.181	1.500	.248	7.283	1.339	7.677	1.850	4.84	25,300
RF10125-S	FK240	4.921	1.142	1.181	1.500	.248	8.858	1.339	9.252	1.850	5.04	25,300
RF10150-S	FK270	5.905	1.142	1.181	1.500	.248	9.843	1.339	10.433	1.850	4.64	25,300
RF10150-S	FK320	5.905	1.142	1.181	1.500	.248	11.811	1.339	12.402	1.850	4.84	25,300
RF6205-S	FK270	6.000	1.374	1.461	1.752	.311	9.843	1.575	10.433	2.087	7.06	41,800
RF12200-S	FK350	7.874	1.374	1.461	1.752	.311	12.992	1.575	13.583	2.087	6.92	41,800
RF17200-S	FK350	7.874	1.579	2.024	2.000	.374	12.992	1.811	13.583	2.283	9.74	55,000
RF17200-S	FK450	7.874	1.579	2.024	2.000	.374	16.929	1.811	17.520	2.283	10.21	55,000
RF26200-S	FK450	7.874	1.752	2.252	2.500	.374	16.929	2.283	17.520	2.677	13.44	70,400

To locate compatible sprockets for your chain, refer to the Product Cross-Reference in Section D.

Note: Dimensions are subject to change. Contact Union Chain to obtain certified prints for design and construction.

## NF Block Chain for Flow Conveyor

Special alloy steel provides greater tensile strength and this chain's simple construction provides greater allowable wear. This chain is ideal for conveying material that is abrasive, wet, or hot. The base chain consists of outer link plates, inner link plates, and pins. Attachments can be welded onto the base chain.

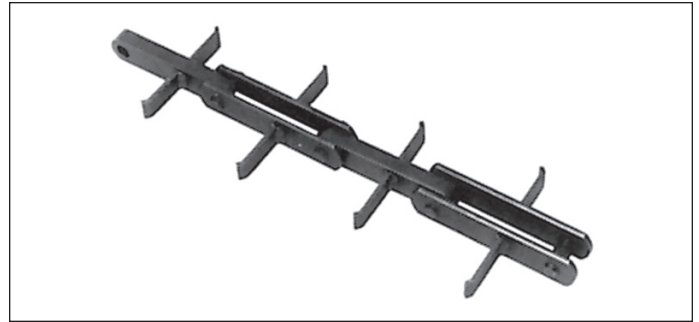

**"L" Attachment**

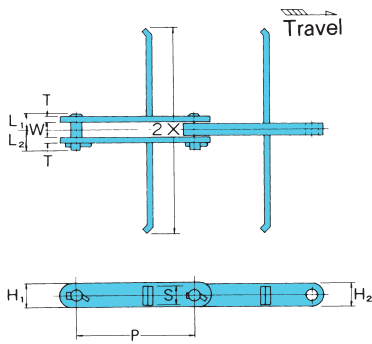

**"KL" Attachment**

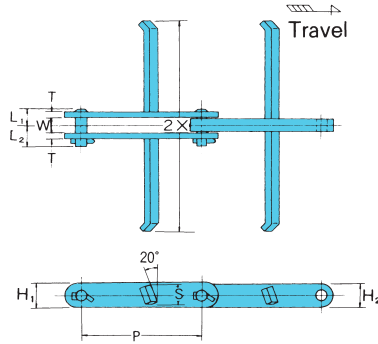

**"W" Attachment**

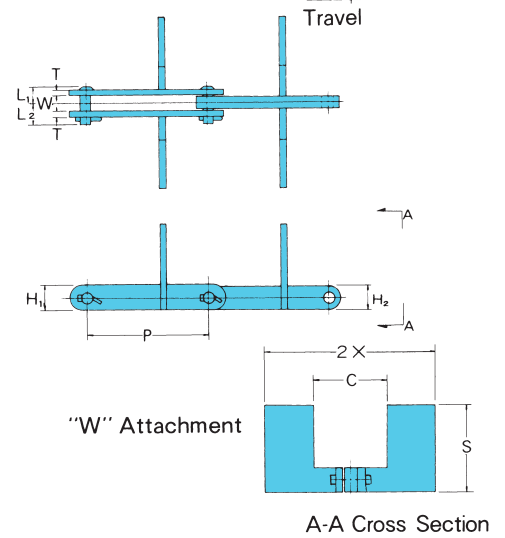

**NF Block Chain Specifications**

All dimensions are in inches unless otherwise indicated.

Chain Number	Pitch	Width Between Outer Link Plates	Link Plate			Pin		Approx. Weight (lbs./ft.)	Average Tensile Strength (lbs./ft.)
			H <sub>1</sub>	H <sub>2</sub>	T	L <sub>1</sub>	L <sub>2</sub>		
	P	W	H <sub>1</sub>	H <sub>2</sub>	T	L <sub>1</sub>	L <sub>2</sub>		
NF30150	5.905	.917	1.752	1.500	.311	.925	1.260	5.31	69,300
NF30200	7.874	.917	1.752	1.500	.311	.925	1.260	5.11	69,300
NF56200	7.874	1.161	2.500	2.126	.374	1.122	1.555	9.88	124,300
NF56250	9.842	1.161	2.500	2.126	.374	1.122	1.555	9.74	124,300

**NF Block Chain Attachment Specifications**

Chain No.	Flow Model No.	"L" Attachment			"KL" Attachment			"W" Attachment			
		2X	S	Additional Weight per Att. (lbs./att.)	2X	S	Additional Weight per Att. (lbs./att.)	2X	S	C	Additional Weight per Att. (lbs./att.)
NF30150	FC150	5.315	1.339	.40	5.315	1.339	.40	5.315	3.150	3.150	.70
NF30150	FC200	7.283	1.339	.57	7.283	1.339	.57	7.283	4.528	3.346	1.50
NF30150	FC270	9.843	1.339	.79	9.843	1.339	.79	9.843	5.512	4.134	2.46
NF30150	FC350	12.992	1.339	1.63	12.992	1.339	1.63	12.992	7.283	5.118	6.47
NF30150	FC450	16.929	1.339	2.16	16.929	1.339	2.16	16.929	9.055	5.315	11.31
NF30200	FC150	5.315	1.339	.40	5.315	1.339	.40	5.315	3.150	3.150	.70
NF30200	FC200	7.283	1.339	.57	7.283	1.339	.57	7.283	4.528	3.346	1.50
NF30200	FC270	9.843	1.339	.79	9.843	1.339	.79	9.843	5.512	4.134	2.46
NF30200	FC350	12.992	1.339	1.63	12.992	1.339	1.63	12.992	7.283	5.118	6.47
NF30200	FC450	16.929	1.339	2.16	16.929	1.339	2.16	16.929	9.055	5.315	11.31
NF56200	FC410	15.354	2.008	2.86	15.354	2.008	2.86	15.354	9.173	3.937	11.00
NF56200	FC450	16.929	2.008	3.17	16.929	2.008	3.17	16.929	9.055	5.315	11.44
NF56200	FC580	22.047	2.008	4.22	22.047	2.008	4.22	22.047	11.417	6.299	18.92
NF56250	FC410	15.354	2.008	2.86	15.354	2.008	2.86	15.354	9.173	3.937	11.00
NF56250	FC450	16.929	2.008	3.17	16.929	2.008	3.17	16.929	9.055	5.315	11.44
NF56250	FC580	22.047	2.008	4.22	22.047	2.008	4.22	22.047	11.417	6.299	18.92

To locate compatible sprockets for your chain, refer to the Product Cross-Reference in Section D.

Note: Dimensions are subject to change. Contact Union Chain to obtain certified prints for design and construction.