



## Quality Components

### High-Strength Sidebars

Sidebars for Tsubaki Drive Chains with an ultimate strength rating higher than 112,000 pounds are manufactured from alloy steel and are thru-hardened; this adds strength and extends the life of the chain. In addition, our advanced manufacturing techniques ensure accurate hole size and precise pitch control, distributing the load equally and providing smooth sprocket interaction.

### Precision Machined Bushing

Bushings for drive chain are precision machined and ground to provide smooth bearing surfaces. They are thru-hardened and/or case hardened to meet your application.

### Alloy Steel Induction Hardened

All Drive Chain Pins are made from alloy steel and are thru-hardened for toughness and strength. In addition, our pins have an induction hardened surface. This provides the best combination of high yield strength and superior wear resistance.

### Shock-Resistant Rollers

Our rollers are made from a high quality material for use when critical tolerances and superior finish are required. Then they are thru-hardened to withstand high shock loads.



INDUSTRY/APPLICATION	MACHINERY
Construction	Crane crawler
Asphalt	Drum drive
Foundry	Drum drive
Sugar Mill	Roll drive
Sugar Mill	Feed roll
Steel Mill	Furnace door
Steel Mill	Steel mill reclaimer for iron ore and coal
Steel Mill	Draw bench
Refinery	Drum drive
Mining	Crusher
Mining	Drilling machine (long hole blasting)
Pulp & Paper	Drum drive, Barking drum

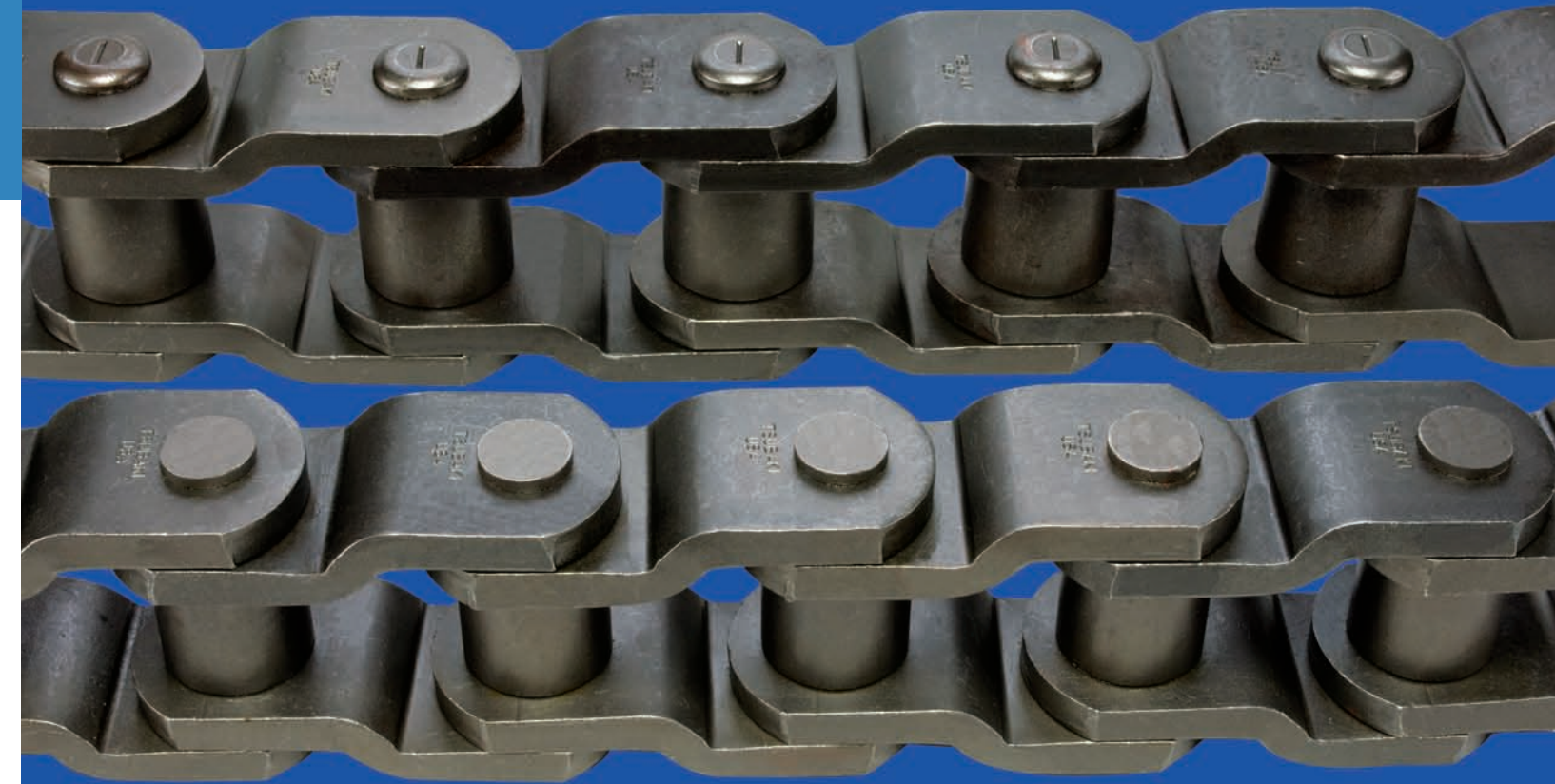

### U. S. Tsubaki, Inc. Headquarters

301 E. Marquardt Drive  
Wheeling, IL 60090  
Phone: (800) 323-7790  
Phone: (847) 459-9500  
Fax: (847) 459-9515

### Roller Chain Holyoke Plant

U. S. Tsubaki, Inc.  
821 Main Street  
Holyoke, MA 01040  
Phone: (800) 628-9037  
Fax: (413) 543-8239

### Engineering Chain Sandusky Plant

U. S. Tsubaki, Inc.  
1010 Edgewater Drive  
Sandusky, OH 44870  
Phone: (800) 537-6140  
Phone: (419) 626-4560  
Fax: (419) 626-5194

sales@ustsubaki.com  
ustsubaki.com



DISTRIBUTED BY:



NOTE: In accordance with the policy of U.S. Tsubaki, Inc. to consistently improve its products, the specifications in this catalog are subject to change without notice. © U.S. Tsubaki, Inc. 2008 All Rights Reserved.

CATALOGUE NUMBER: L0820000  
Printed in U.S. 03/08



# Engineering Class Drive Chain

Driving Excellence in Your Operation



# Engineering Class Drive Chain



## Keep your Operation moving with Tsubaki Chain

Tsubaki Drive Chains are designed to exceed the listed ultimate strength ratings. These ratings are very significant. Chains with greater ultimate strength have higher actual yield and greater fatigue strength. With Tsubaki Chains, you get extra reserve strength to withstand high shock loads.

## Precision Manufacturing Means Greater Fatigue Strength

Tsubaki Engineering Class Drive Chains are built to withstand the most rugged conditions. We use the latest manufacturing and heat-treating techniques to manufacture every component. Each component is carefully manufactured to close tolerances to ensure precise pitch control for smooth sprocket/chain interaction. That means, longer service life for chain and sprockets.

## Add the Power of Alloy

When parts require high ultimate strength, we use alloy steel to make the components. This provides more uniform core strength, which is particularly important for heavy duty applications. Every Tsubaki Drive Chain with an ultimate strength rating higher than 112,000 pounds is made entirely of alloy steel. All Tsubaki Drive Chains are furnished with alloy steel pins.

## Reduce Maintenance Costs and Downtime

Tsubaki Drive Chains stand up to the toughest environments for hour after hour of uninterrupted service

- Optimum strength
- Alloy steel parts
- Accurate pitch control
- Fatigue resistant
- Press fit construction
- Pre-lubricated
  - Pin-Roller
  - Pin-Bushing

## Drive Chain Specifications

All dimensions are in inches unless otherwise indicated.

Chain No.	Pitch	Sty. <sup>1</sup>	ANSI No.	Pin End to CL	Pin Head to CL	Inside Width	Pin			Roller		Sidebar			Bushing		Stocked Lengths		Avg. Ult. Sigth. (lbs.)	Max Work Load (lbs.)	Appx. Weight (lbs./ft.)
							Dia.	Sty. <sup>2</sup>	Matl. <sup>3</sup>	Dia.	Matl. <sup>3</sup>	Hgt.	Th.	Matl. <sup>2</sup>	Dia.	Matl. <sup>3</sup>	Pitches	Feet			
US-2065	2.000	0		1.69	1.44	1.27	.59	K	AHTIH	1.13	AHT	1.63	.31	AHT	.81	ACH	60	10.00	65,000	4,000	7.6
RO-3140	1.750	0		1.41	1.19	1.00	.55	K	AHT	1.00	AHT	1.70	.25	AHT	.76	ACH	69	10.00	57,000	2,800	6.5
RO-3160	2.000	0		1.53	1.31	1.25	.54	K	AHT	1.13	AHT	1.94	.25	AHT	.80	ACH	60	10.00	67,300	3,450	6.7
RO-3180	2.250	0		1.74	1.47	1.44	.69	K	AHT	1.41	AHT	2.13	.28	AHT	1.00	CCH	53	10.00	80,000	4,800	9.6
RO-25H	2.500	0		1.96	1.71	1.50	.65	K	AHTIH	1.25	AHT	1.63	.38	AHT	.91	ACH	48	10.00	87,000	4,900	9.2
520RX	2.563	0		1.44	1.22	1.06	.50	A	CHT	1.13	CHT	1.25	.25	CHT	.75	ACH	47	10.00	25,000	2,800	4.8
US-882	2.609	0		1.44	1.25	1.13	.44	K	AHT	.88	AHT	1.13	.25	CHT	.64	ACH	46	10.00	26,000	2,500	3.6
US-3011	3.067	0	2512	2.13	1.75	1.56	.75	K	AHTIH	1.63	AHT	2.25	.38	AHT	1.12	ACH	39	10.00	110,000	6,100	12.0
US-1030	3.075	0		1.84	1.56	1.50	.63	K	AHTIH	1.25	AHT	1.50	.31	HC	.90	ACH	39	10.00	28,000	4,650	7.0
US-1031	3.075	0		1.84	1.59	1.50	.63	K	AHTIH	1.25	AHT	1.50	.31	CHT	.90	ACH	39	10.00	48,000	4,650	7.0
US-3075	3.075	0		2.00	1.72	1.50	.65	K	AHTIH	1.25	AHT	1.75	.38	AHT	.91	ACH	39	10.00	75,000	5,100	9.6
US-3514	3.500	0	2814	2.38	2.03	1.50	.88	K	AHTIH	1.75	AHT	2.25	.50	AHT	1.25	ACH	34	9.90	140,000	7,700	16.1
US-1241	4.063	0		2.56	2.25	1.94	.88	K	AHTIH	1.75	AHT	2.25	.50	AHT	1.25	ACH	30	10.20	112,000	9,000	16.3
US-1242	4.063	0		2.56	2.25	1.94	.88	K	AHTIH	1.75	AHT	2.25	.50	AHT	1.25	ACH	30	10.20	140,000	9,000	16.1
US-1245	4.073	0	3315	2.75	2.38	1.94	.94	K	AHTIH	1.78	AHT	2.38	.56	AHT	1.31	ACH	30	10.20	170,000	10,100	18.0
US-4121	4.090	0		2.75	2.38	1.94	1.00	K	AHTIH	1.88	AHT	2.75	.56	AHT	1.39	AHT	30	10.20	210,000	10,700	13.6
US-4122	4.090	0		2.75	2.38	1.94	1.10	K	AHTIH	2.00	AHT	2.75	.56	AHT	1.50	AHT	30	10.20	235,000	11,700	14.0
US-4522	4.500	0	3618	2.88	2.45	2.06	1.10	K	AHTIH	2.25	AHT	3.00	.56	AHT	1.62	AHT	27	10.10	220,000	12,300	25.4
US-5031	5.000	0	4020	3.38	3.06	2.75	1.25	K	AHTIH	2.50	AHT	3.50	.63	AHT	1.75	ACH	24	10.00	310,000	17,500	34.0
US-5035	5.000	0		3.51	3.08	2.56	1.38	K	AHTIH	2.50	AHT	3.50	.75	AHT	1.88	AHT	24	10.00	350,000	19,600	38.1
US-5542	5.500	0		3.85	3.41	3.00	1.50	K	AHTIH	3.00	AHT	4.00	.75	AHT	2.00	AHT	62	28.40	420,000	23,600	49.1
US-5738	5.750	0		3.69	3.31	3.00	1.50	K	AHTIH	3.00	AHT	4.00	.69	AHT	2.00	AHT	21	10.10	380,000	23,000	46.0
US-6042	6.000	0	4824	3.85	3.41	3.00	1.50	K	AHTIH	3.00	AHT	4.00	.75	AHT	2.00	AHT	20	10.00	420,000	23,600	45.0
US-6066	6.000	0		3.83	3.55	3.00	1.75	K	AHTIH	—	—	4.75	.75	AHT	3.00	AHT	57	28.50	600,000	27,600	51.7
US-64S	2.500	S		2.00	1.69	1.50	.88	K	AHT	1.56	AHT	2.13	.38	AHT	1.19	ACH	48	10.00	125,000	6,900	13.1
344SXX	3.000	S		2.75	2.38	1.94	.94	K	AHTIH	1.78	AHT	2.38	.56	AHT	1.31	ACH	40	10.00	170,000	10,050	22.0
US-4031	4.000	S		3.34	2.91	2.75	1.25	K	AHTIH	2.50	AHT	3.50	.63	AHT	1.75	ACH	30	10.00	310,000	17,500	40.0
US-1353	4.090	S		3.09	2.66	2.19	1.31	K	AHTIH	2.63	AHT	3.50	.63	AHT	1.88	ACH	30	10.20	210,000	16,000	37.6
US-5042	5.000	S		3.85	3.41	3.00	1.50	K	AHTIH	3.00	AHT	4.00	.75	AHT	2.00	AHT	24	10.00	420,000	23,600	53.0
US-6566	6.500	S		4.36	3.95	3.19	1.75	K	AHTIH	3.50	AHT	6.00	.88	AHT	2.44	AHT	36	19.50	600,000	30,600	71.1

<sup>1</sup>Indicates chain is normally stocked. All others made to order.  
<sup>2</sup>Style: O= offset sidebar; S=straight sidebar  
<sup>3</sup>Pin Style: K=Full round; A=Double flat  
<sup>4</sup>Material: HC=High carbon; CHT=Carbon heat treated; AHT= Alloy heat treated; AHTIH=Alloy heat treated and induction hardened; CCH=Carbon case hardened; ACH=Alloy case hardened

Note: Dimensions are subject to change. Contact Union Chain to obtain certified prints for design and construction.

# Drive Chain

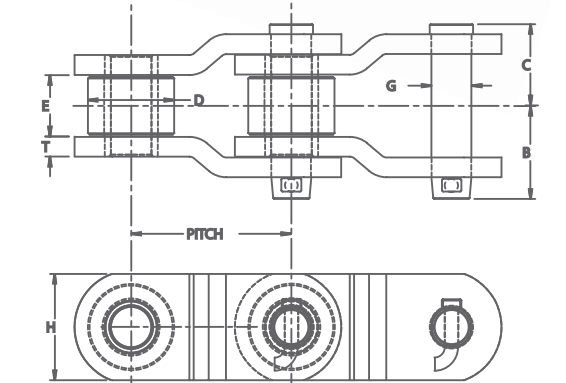
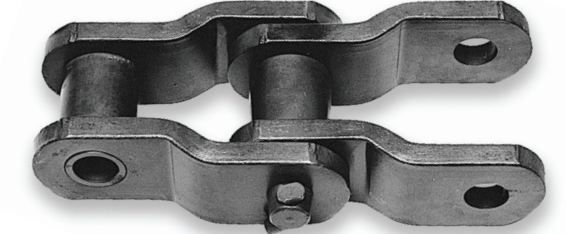
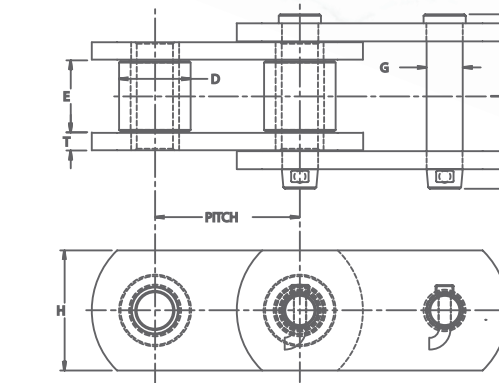
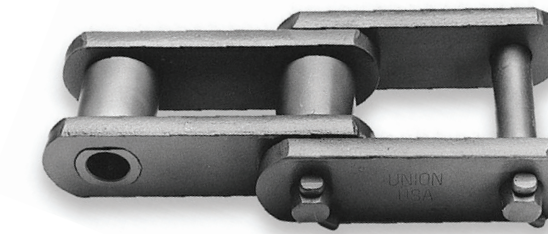

## Engineering Class Sprockets

Engineering class chains and sprockets must work together, so buying them from the same source makes sense. When chains and sprockets articulate correctly, you get longer service life from your chain. That means long-term savings and real value for your operation. Chain life is only as good as the sprocket that drives it, so maximize your operation with Engineering Class Sprockets from U.S. Tsubaki.



To help determine the proper drive chain, the following list is provided:

INTERCHANGE DATA					
DESCRIPTION	PITCH	ALLIED LOCKE	RENOLD/JEFFERY	LINK BELT	REXNORD
US-1030	3.075	—	JS1030	RO40	1030
US-1031	3.075	MXS1031	JS1031	RO1031	R1033
US-1242	4.063	MXS1242	JS4014	LXS1242M	R1248
US-1245	4.073	MXS1245	JS1245A	RO3315	RX1245
US-2065	2.000	MXS2065	IS2065R	RO3160S	B3113
US-3011	3.067	MXS3011	JS3011	RO2512	AX1568
US-3075	3.075	MXS3075	JS3075	RO40HYPER	R1037
US-3514	3.500	MXS3514	JS3514	RO2814	RX238
US-4522	4.500	MXS4522	IS4522	RO3618	RO635
US-5031	5.000	MXS5031	JS5031	RO4020	RO1207
US-5035	5.000	MXS5035	1605AAA		RO1315
US-5042	5.000	—	—		
US-5542	5.500	MXS5542	—		RO1356
US-6042	6.000	MXS6042	JS6042	RO4824	RX1306
US-6066	6.000	MXS6066	—		
US-882	2.609	MXS882	JS882	LSX882	R588

For information on Drive Chain selection guidelines visit [ustsubaki.com](http://ustsubaki.com) and refer to page A5 – A15 of our main catalog.