

TSUBAKI



POWER-LOCK[®]

www.ustsubaki.com

Tsubaki POWER-LOCK® Keyless Shaft Locking Solutions

Performance Under Pressure

Tsubaki's extensive POWER-LOCK® portfolio offers a simple and cost effective solution to problems associated with keyed or machined drive shafts. Incorporating POWER-LOCK® technology into existing and new designs provides increased shaft strength while reducing machining and maintenance costs. Tsubaki's POWER-LOCK® eliminates backlash damage to keyways and specialty machined bores in applications that experience reversing loads or high torque. In addition, machining expenses associated with keyways, spline bores, steps and snap ring grooves can be removed from the equation. This easy to install device is ideal for locking large or small sprockets, gears, pulleys, timing cams, and rollers.

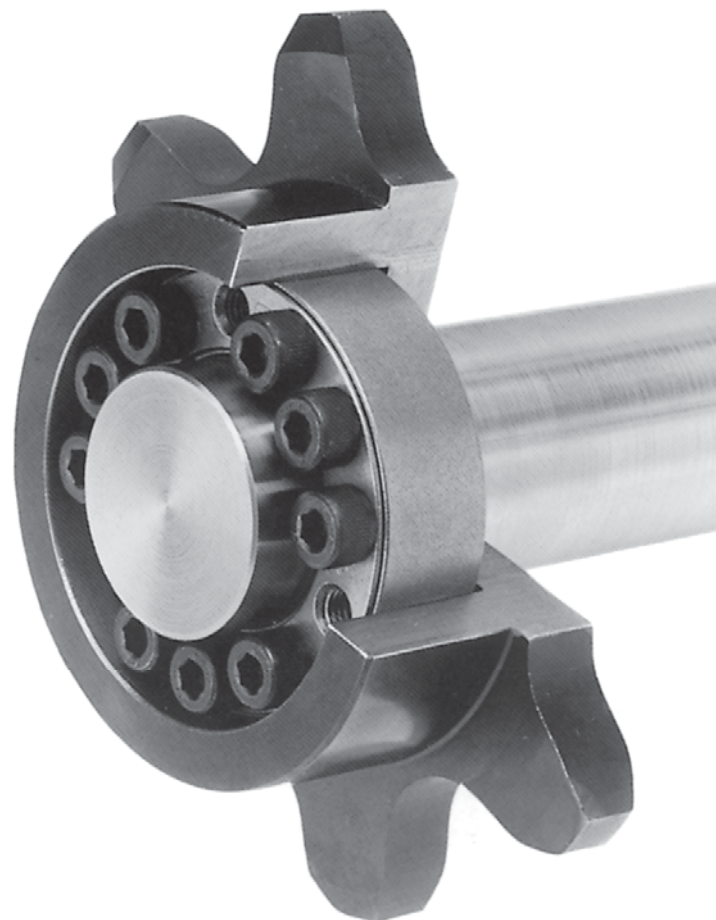

POWER-LOCK® Features & Benefits

- Broad range of product available in inch and metric shaft sizes up to 11 1/16 (300mm).
- Available in high grade carbon steel, stainless steel, and electroless nickel plating for maximum corrosion resistance.
- Ideal for applications that experience directional reversing and impact loads.
- Thrust load capability: Tsubaki POWER-LOCK® technology is designed to handle axial forces that would normally be detrimental to keyed and specialty machined bore sprockets, gears, and timing pulleys.
- Easy assembly and disassembly allows for fast installation and removal.
- Tsubaki POWER-LOCK® technology physically increases shaft strength and provides longer service life.
- Costly machining is eliminated. The need for costly machining of keyways, specialty bores, and machining center set-up is not required.
- Tsubaki POWER-LOCK® can be ordered in self centering , flanged, or flush mounting configurations to save time and reduce dimensional envelope requirements.
- The task of positioning a sprocket, gear, or pulley is simplified.
- Several Tsubaki POWER-LOCK® Series' come with built in tap holes for ease of removal.
- Tsubaki POWER-LOCK® technology can be reused in applications that require frequent service or inspection.

Multi-purpose

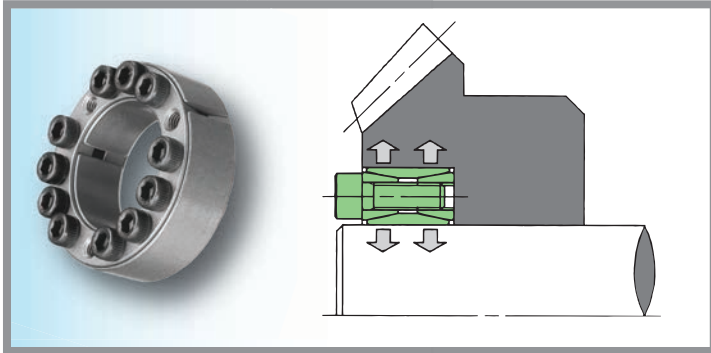

AS Series

- Global standard for keyless shaft locking
- Available in inch and metric sizes from ¾" (19mm) to 11 1/16" (300mm)
- Simple construction allows for easy installation
- Built in tap holes for easy removal
- Transmissible torque range from 188 ft. lbs. to 111,400 ft. lbs.

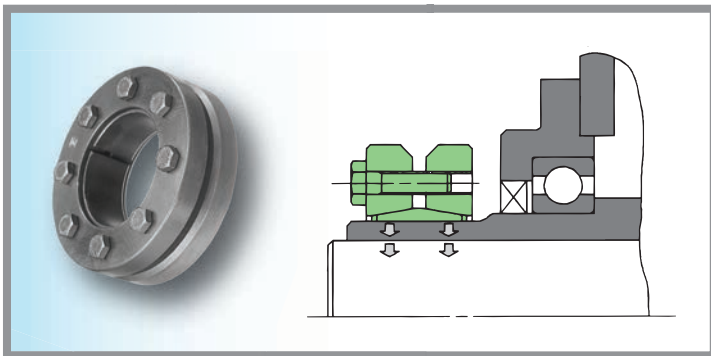

SL Series

- External locking for hollow shaft applications
- Ideal for applications with limited space available
- Available in metric sizes from 24mm to 300mm
- Simple construction allows for easy installation and removal
- Transmissible torque range from 123 ft. lbs. to 213,893 ft. lbs.

Corrosion Resistant

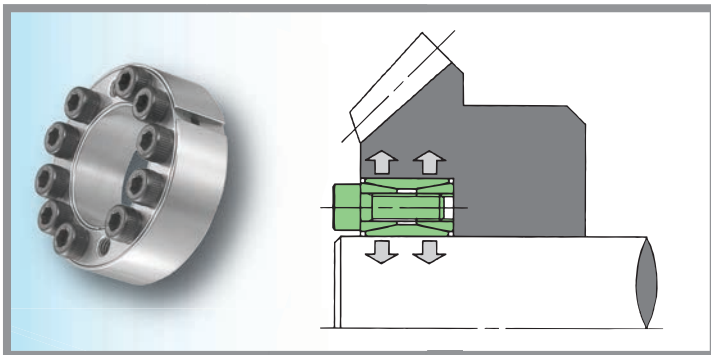

AS-SS Series

- Fully interchangeable with AS Series
- 100% stainless steel construction
- Available in inch and metric sizes from ¾" (19mm) to 4" (150mm)
- Simple construction allows for easy installation
- Built in tap holes for easy removal
- Transmissible torque range from 151 ft. lbs. to 6,417 ft. lbs.

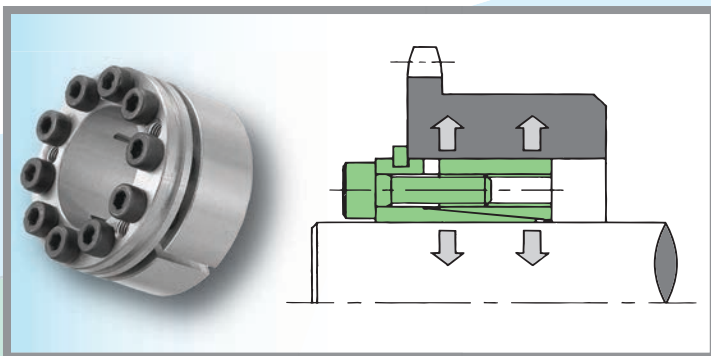

RE-SS Series

- Available in flanged or flush type configuration
- Austenite stainless steel designed to handle the most corrosive environments and clean room applications
- Available in metric sizes from 5mm to 50mm
- Built in tap holes for easy removal
- Transmissible torque range from 4 ft. lbs. to 1,490 ft. lbs.

Self Centering

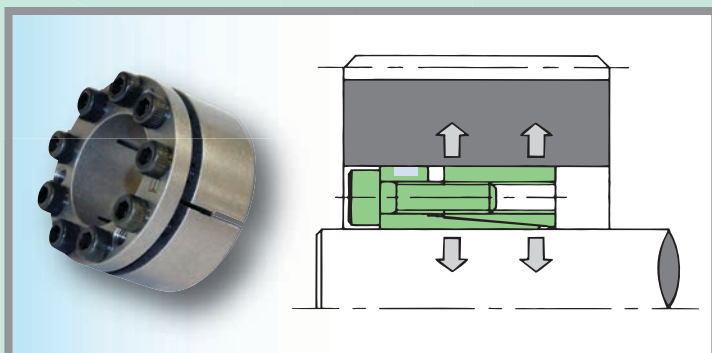
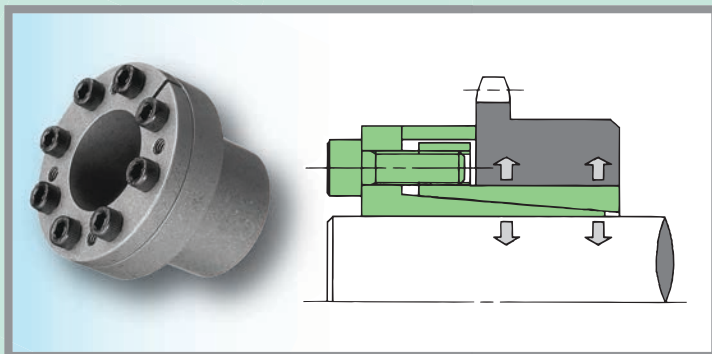
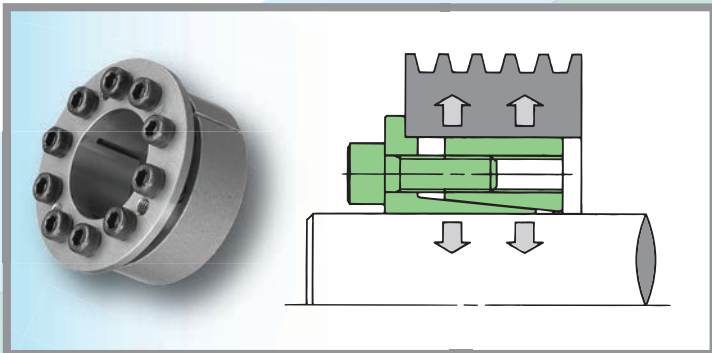
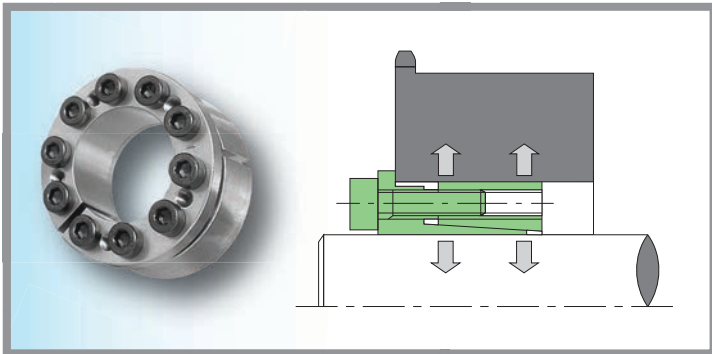
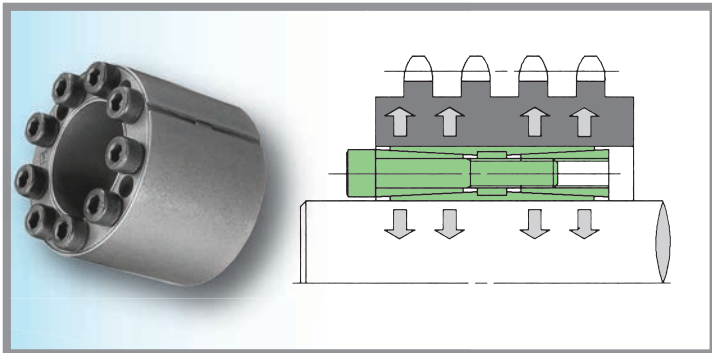

AD Series

- Offers the greatest allowable transmissible torque of all Tsubaki POWER-LOCK® products
- Ideal for multi-strand or large hub sprockets & gears
- Available in inch and metric sizes from ¾" (19mm) to 11 1/16" (300mm)
- Built in tap holes for easy removal
- Transmissible torque range from 283 ft. lbs. to 316,453 ft. lbs.

KE Series

- Ideal for "A" style sprockets and narrow gears
- Available in inch and metric sizes from ¾" (5mm) to 4" (150mm)
- Built in tap holes for easy removal
- Available with electroless nickel plating
- Transmissible torque range from 22 ft. lbs. to 7,460 ft. lbs.

AE Series

- Ideal for narrow hubs, gears, and pulleys
- Flanged design allows for fast installation
- Interchangeable with AS Metric Series
- Available in inch and metric sizes from ¾" (19mm) to 4" (150mm)
- Built in tap holes for easy removal
- Transmissible torque range from 195 ft. lbs. to 19,914 ft. lbs.

TF Series

- Designed for small hub diameters
- Long taper of the inner ring allows for accurate shaft to hub alignment
- Available in metric sizes from 50mm to 90mm
- Built in tap holes for easy removal
- Transmissible torque range from 8 ft. lbs. to 6,505 ft. lbs.

FL Series

- Designed for straight and narrow hubs
- Fully interchangeable with AS Series inch and metric
- Available in metric sizes from ¾" (19mm) to 4" (100mm)
- Built in tap holes for easy removal
- Transmissible torque range from 201 ft. lbs. to 9,470 ft. lbs.

Tsubaki POWER-LOCK® Applications

The Tsubaki POWER-LOCK® is used in many applications throughout the world to satisfy the need for keyless shaft locking requirements. Our customers frequently discover new applications where a POWER-LOCK® provides an ideal alternative to expensive machining while improving performance and reducing maintenance costs. The following illustrations provide just a few examples of how a Tsubaki POWER-LOCK® may be applied.

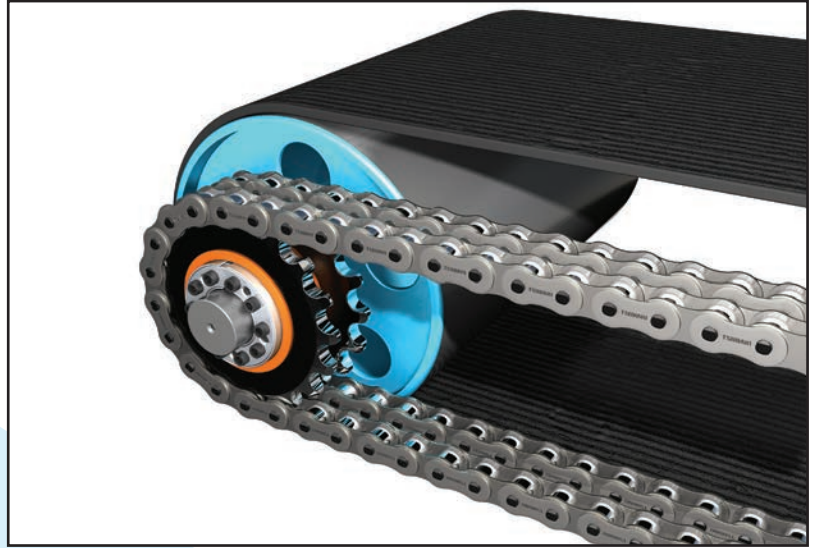

AS Series used on a conveyor drive.

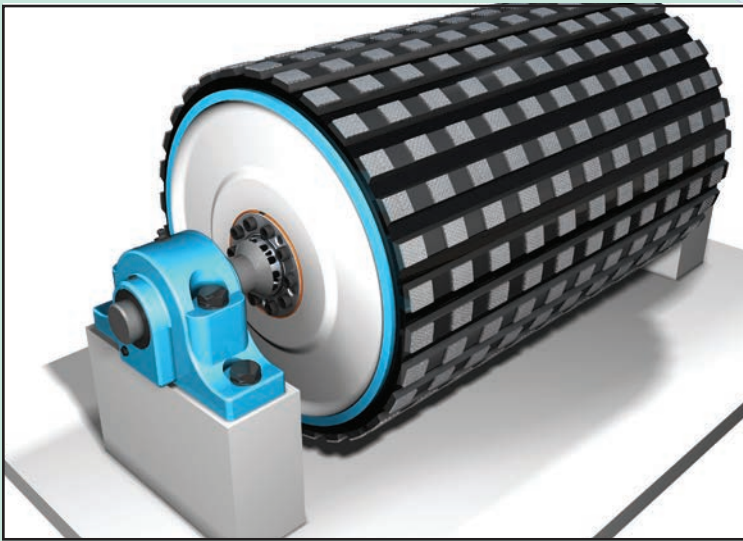

AD Series used on a mining conveyor drum.

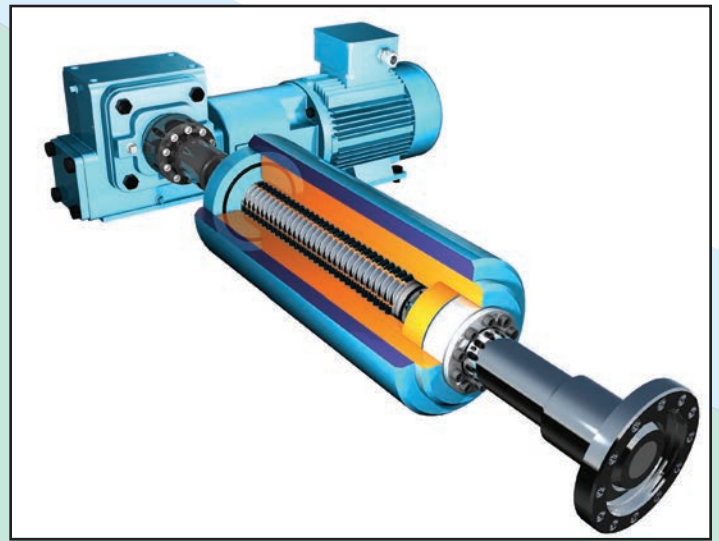

AS Series used on an industrial drive.

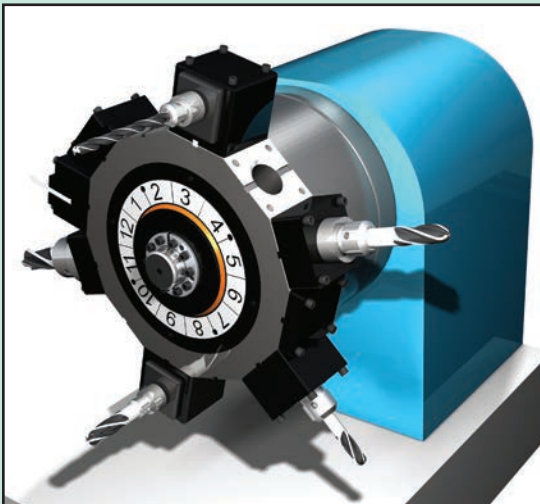

AE Series used on a machine tool turret.

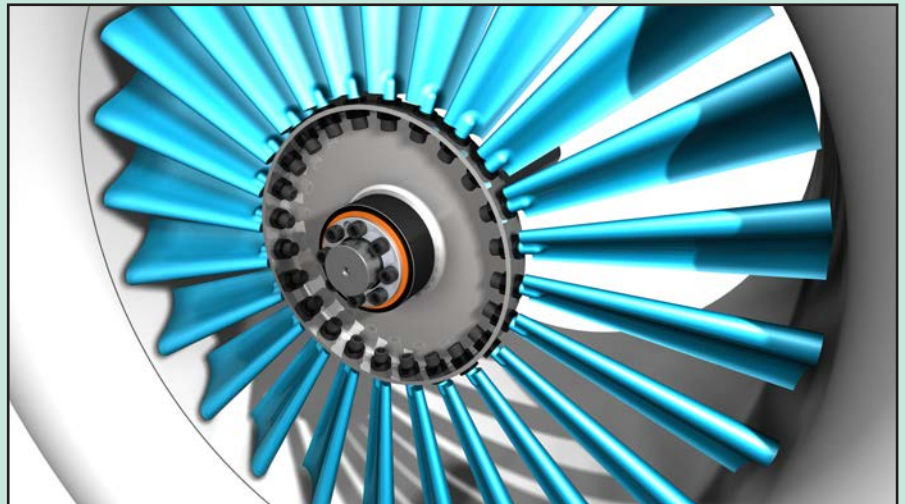

KE Series used on an industrial fan.



A World of Opportunity

Kyotanabe City, Japan
Manufacturing and research center



The most advanced chain production facility in the world

Our global presence means unprecedented opportunities

- Develop and market advanced new products and technologies
- Use intellectual assets from around the world



Corporate Headquarters
U.S. Tsubaki Power Transmission, LLC.
 301 E. Marquardt Drive
 Wheeling, IL 60090
 Tel: (800) 323-7790
 Fax: (847) 459-9515
www.ustsubaki.com



Roller Chain Division
 821 Main Street
 Holyoke, MA 01040
 Tel: (800) 323-7790



Conveyor and Construction Chain Division
 1010 Edgewater Drive
 Sandusky, OH 44870
 Tel: (800) 537-6140
 Fax: (419) 626-5194



Sprocket Manufacturing
 1630 Drew Road
 Mississauga, Ontario
 L5S 1J6 Canada
 Tel: (800) 323-7790



Cable and Hose Carrier Division
 7100 W. Marcia Road
 Milwaukee, WI 53223
 Tel: (800) 443-4216
 Fax: (413) 354-1900