

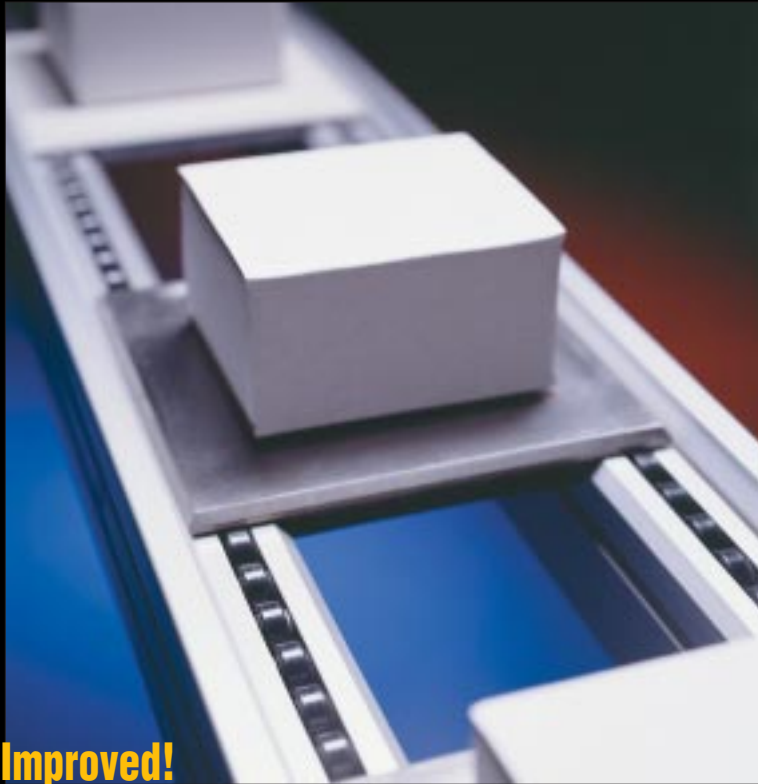

**U.S. Tsubaki, Inc.**

Roller Chain Division

# DOUBLE PLUS<sup>®</sup> Chain



**Unique  
Patented  
Design**

**Improved!**

**For Free Flow Conveying and  
Accumulating Applications**

**INCREASE EFFICIENCY AND OUTPUT**

**REDUCE OPERATING COSTS**

**ACCELERATE YOUR OPERATION**

# DOUBLE PLUS<sup>®</sup> Chain

Revolutionary Technology

Maximize your operation with  
DOUBLE PLUS Chain from U.S. Tsubaki.

Now you can increase production  
and efficiency without increasing labor costs.

If you're running a conveying or  
accumulating line, DOUBLE PLUS from U.S.  
Tsubaki with its unique, patented design can  
mean real savings for your operation.

## How DOUBLE PLUS® Works

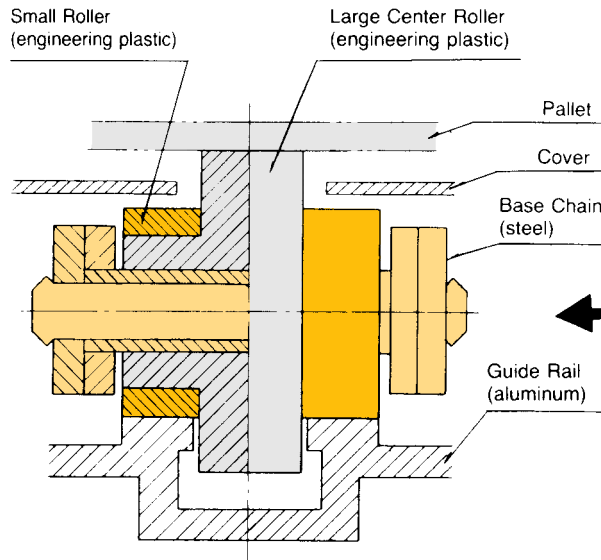

Cutaway view of DOUBLE PLUS® roller

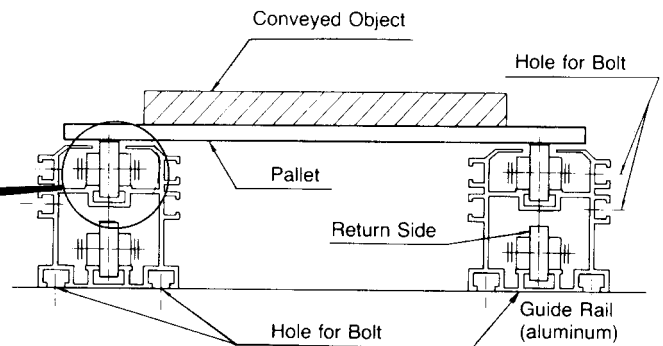

End view of DOUBLE PLUS® system

DOUBLE PLUS Chain uses free flow technology to revolutionize your operation. The secret is in the construction.

DOUBLE PLUS consists of a series of rollers: a large center roller and two small outer rollers. Rollers can be made of engineered plastic for low-maintenance, low-noise operations or steel for heavy-duty applications.

### Technology Leads to Real Savings

Faster pallet speed can mean savings. You can use slower chain speeds and smaller motors, yet get the same — or faster — output. Chains last longer and you can reduce operating costs. DOUBLE PLUS lets you maintain or even increase production while lowering costs.

Friction between the large roller and the small rollers allows them to turn in unison. The difference in roller diameters results in the

conveyed object moving about 2.5 times FASTER than the speed of the chain. That means you get increased output without increasing the speed of your chain.

The large roller supports the pallet. The small rollers rotate on the guide rail and provide rolling friction. They keep the chain moving even when pallets are accumulating. Smooth accumulation protects product on line.

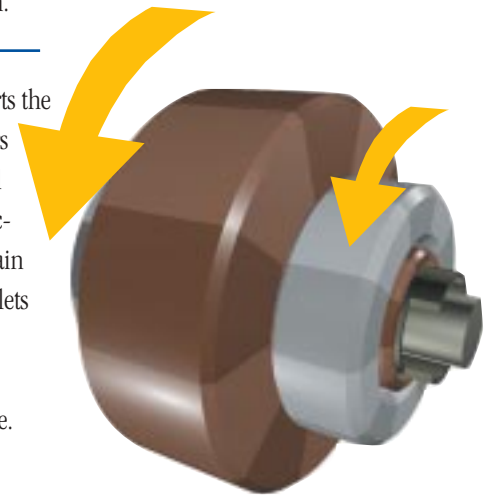

DOUBLE PLUS® rollers

# A DOUBLE PLUS® System

## DOUBLE PLUS®

- **Maintain or accelerate production without increasing labor or shifts.**
- **Reduce operating costs.**
- **Choose the right type from the wide selection available.**
- **Enhance worker comfort and productivity with lower noise levels.**
- **Protect your products and your people with the safe, enclosed DOUBLE PLUS system.**
- **Get up and running quickly because DOUBLE PLUS is easy to install.**

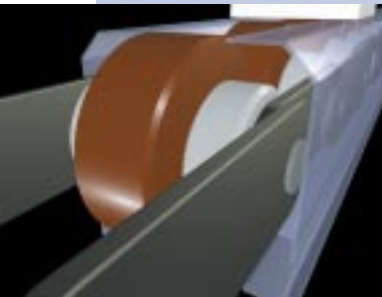

## A System for Speed

DOUBLE PLUS® is a system of parts that come together to maximize efficiency at your operation. The system includes:

- Revolutionary DOUBLE PLUS Chain (see pages 4 and 6)
- Special 10-tooth sprockets — a unique geometry available for sizes 3/4" to 2" (see page 5). This unique geometry is also available for Engineering Class DOUBLE PLUS Chain in 6- or 8-tooth sprockets (see page 7)
- Plastic return guides — help maintain low noise levels and ensure a smooth transition (see page 8)
- Brackets — allow convenient installation of plastic return guides (see page 9)
- Anodized aluminum guide rail with optional steel rail inserts (see page 10)
- Pallet guide rails — protect your products by keeping them securely on the system (see page 11)

## Select the right base chain.

The chain can be constructed from three different types of materials. Choose carbon steel for general purpose applications, stainless steel when corrosion resistance is required, or hard chrome plated when you want the strength of carbon steel with light corrosion resistance. For larger applications (over 840 lbs. of tension and 270 lbs. per roller capacity), U.S. Tsubaki offers Engineering Class DOUBLE PLUS Chain.

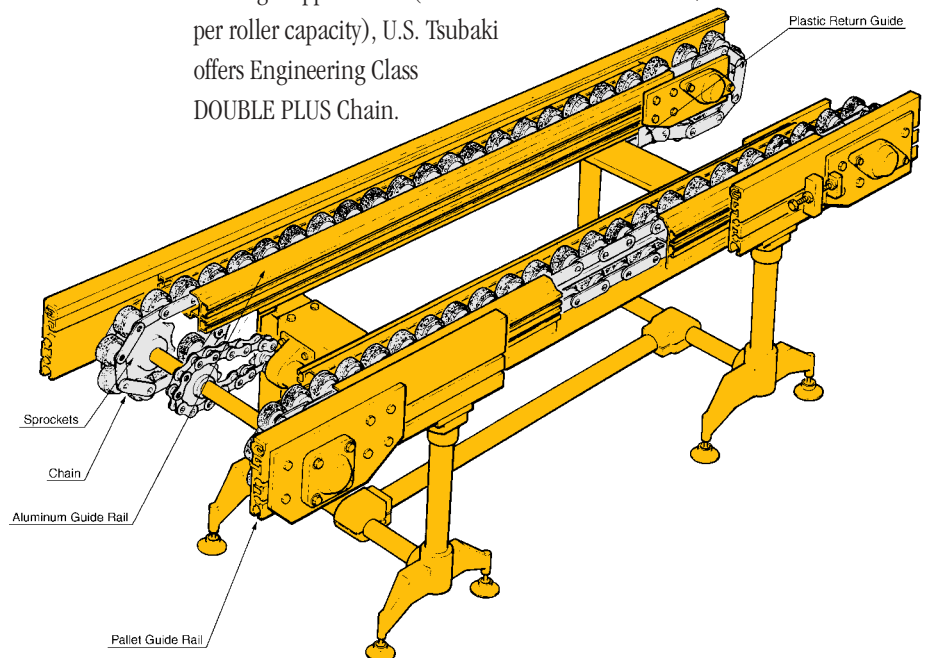
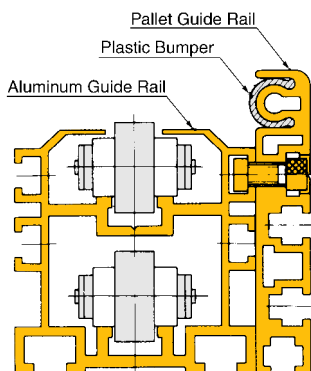

## Choose the right size.

DOUBLE PLUS® with plastic rollers is available in 3/4" pitch to 2" pitch. DOUBLE PLUS with steel rollers is available in 3/4" pitch to 7-7/8" pitch.

## Choose the right rollers.

Select the type of rollers that will work best for your operation.

Our **A series** rollers meet most standard applications. **B series** is made of high-friction plastic for quick startup, **C series** discharges electrostatic buildup, and **D series** offers quick startup and discharge of electrostatic buildup. Urethane rollers are available on a specialty basis to prevent scratching of sensitive products when conveying without pallets. Consult your U.S. Tsubaki Product Engineer for more details.



Urethane rollers

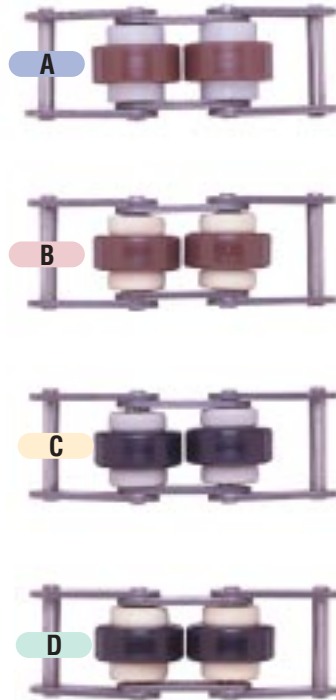

SERIES:	SIZE OF ROLLER:		SERIES BENEFITS:
	SMALL	LARGE	
<b>A</b>	<i>Color:</i> Gray	Brown	Maximum Allowable Tension
	<i>Feature:</i> Standard	Standard	
<b>B</b>	<i>Color:</i> Off-White	Brown	Quick Start-up
	<i>Feature:</i> High friction plastic	Standard	
<b>C</b>	<i>Color:</i> Gray	Black	Volume Resistivity of $10^6 \Omega \times \text{cm}$
	<i>Feature:</i> Standard	Electroconductive Plastic	
<b>D</b>	<i>Color:</i> Off-White	Black	Quick Start-up AND Volume Resistivity of $10^6 \Omega \times \text{cm}$
	<i>Feature:</i> High friction plastic	Electroconductive Plastic	

## Special Option

DOUBLE PLUS with snap covers is also available. Snap covers prevent small parts from falling into the line and jamming the conveyor.



DOUBLE PLUS® with Snap Covers



# Specifications

## STANDARD

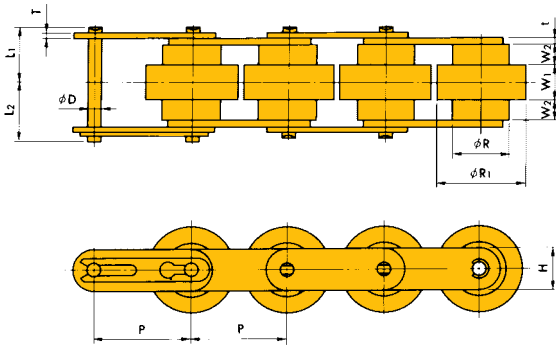

## DOUBLE PLUS® WITH SNAP COVERS

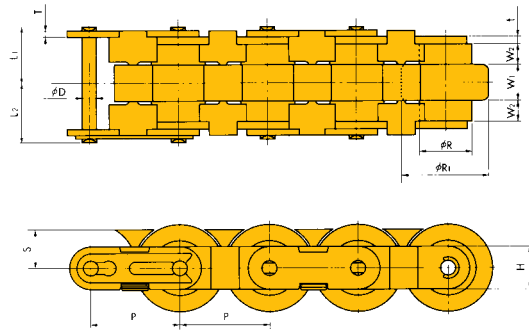

- These base chains are specialized for SNAP COVERS.
- The SNAP COVERS cannot be attached to the standard type of DOUBLE PLUS chain.
- Offset links are not available for DOUBLE PLUS with SNAP COVERS.

## DOUBLE PLUS® CHAIN

Upper dimensions-inches  
Lower dimensions-mm

Chain No.	P	R	R <sub>1</sub>	W <sub>1</sub>	W <sub>2</sub>	t	T	H	D	L <sub>1</sub>	L <sub>2</sub>	Approx. Weight lbs./ft. (kg/m)		
												Plastic Roller	Steel Roller	
C2030VR														
C2030VRP	0.75	0.469	0.720	0.315	0.157	0.060	0.060	0.354	0.141	0.474	0.522	0.40	0.94	
C2030VR-SC	(19.05)	(11.91)	(18.3)	(8.0)	(4.0)	(1.5)	(1.5)	(9.0)	(3.59)	(12.05)	(13.25)	(0.6)	(1.4)	
C2030VRP-SC														
C2040VR														
C2040VRP	1.00	0.625	0.969	0.406	0.224	0.080	0.060	0.472	0.156	0.622	0.669	0.67	1.68	
C2040VR-SC	(25.40)	(15.88)	(24.6)	(10.0)	(5.7)	(2.0)	(1.5)	(12.0)	(3.97)	(15.80)	(17.00)	(1.0)	(2.5)	
C2040VRP-SC														
C2050VR														
C2050VRP	1.25	0.750	1.205	0.512	0.280	0.094	0.080	0.591	0.200	0.770	0.837	0.94	2.49	
C2050VR-SC	(31.75)	(19.05)	(30.6)	(13.0)	(7.1)	(2.4)	(2.0)	(15.0)	(5.09)	(19.55)	(21.25)	(1.4)	(3.7)	
C2050VRP-SC														
C2060VR														
C2060VRP	1.50	0.875	1.441	0.610	0.335	0.125	0.125	0.677	0.234	0.964	1.039	1.34	3.76	
C2060VR-SC	(38.10)	(22.23)	(36.6)	(15.5)	(8.5)	(3.2)	(3.2)	(17.2)	(5.96)	(24.5)	(26.4)	(2.0)	(5.6)	
C2060VRP-SC														
C2080VRP	2.00	1.125	1.890	0.787	0.591	0.156	0.156	0.906	0.312	1.409	1.496	2.62	—	
C2080VRP-SC	(50.80)	(28.58)	(48.0)	(20.0)	(15.0)	(4.0)	(4.0)	(23.0)	(7.94)	(35.8)	(38.0)	(3.9)	—	

- Steel roller type (VR series) is available for 14°F to 302°F (-10°C to +150°C).
- Plastic roller type (VRP series) is available for 14°F to 140°F (-10°C to +60°C).

## STANDARD

A unique geometry available for sizes 3/4" to 2" pitch.

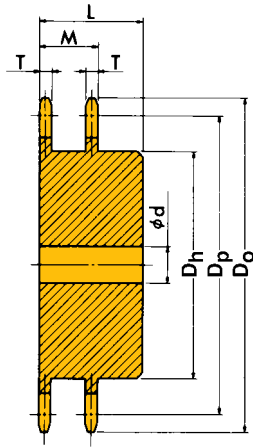

## Sprockets for DOUBLE PLUS® CHAIN

(For Double Pitch "VR," "VRP," "VR-SC," & "VRP-SC")

Upper dimensions-inches  
Lower dimensions-mm

Sprocket No.	Hub Type	Number of Teeth	Pitch Dia. D <sub>p</sub>	Outer Dia. D <sub>o</sub>	Tooth Thickness T	Stock Bore Dia. d	Hub Dia. D <sub>h</sub>	Hub Length L	M	Approx. Weight lbs. (kg)
C2030VRP-10T-SC	B	10	2.427 (61.65)	2.480 (63)	0.118 (3.0)	0.500 (12.7)	1.457 (37)	0.984 (25)	0.602 (15.3)	0.44 (0.2)
C2040VRP-10T-SC	B	10	3.236 (82.20)	3.346 (85)	0.157 (4.0)	0.630 (16)	2.047 (52)	1.575 (40)	0.803 (20.4)	1.76 (0.8)
C2050VRP-10T-SC	B	10	4.045 (102.75)	4.213 (107)	0.197 (5.0)	0.630 (16)	2.598 (66)	1.772 (45)	1.004 (25.5)	3.31 (1.5)
C2060VRP-10T-SC	B	10	4.854 (123.30)	5.039 (128)	0.236 (6.0)	0.748 (19)	3.189 (81)	1.969 (50)	1.201 (30.5)	5.52 (2.5)
C2080VRP-10T-SC	B	10	6.472 (164.39)	6.772 (172)	0.472 (12.0)	0.906 (23)	4.331 (110)	2.638 (67)	1.870 (47.5)	15.4 (7.0)

# Specifications

## ENGINEERING CLASS

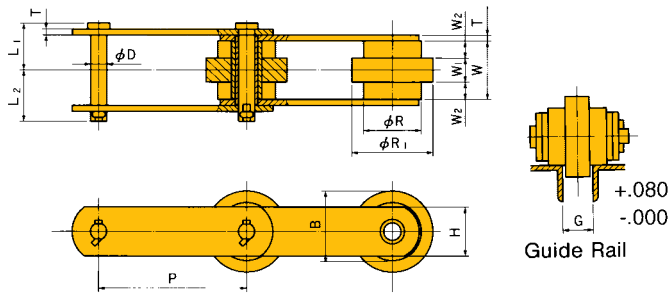

## Engineering Class DOUBLE PLUS® CHAIN

Upper dimensions-inches  
Lower dimensions-mm

Chain No.	P	R	R <sub>1</sub>	W <sub>1</sub>	W <sub>2</sub>	W	T	H	D	L <sub>1</sub> +L <sub>2</sub>	L <sub>1</sub>	L <sub>2</sub>	B	G	Approx. Weight lbs./ft. (kg/m)
RF03075VR	2.953 (75)	1.252 (31.8)	1.654 (42.0)	0.472 (12)	0.335 (8.5)	1.181 (30)	0.126 (3.2)	0.866 (22.0)	0.315 (8.00)	2.028 (51.5)	0.965 (24.5)	1.063 (27.0)	1.453 (36.9)	0.571 (14.5)	3.16 (4.7)
RF03100VR	3.937 (100)														2.69 (4.0)
RF05100VR	3.937 (100)	1.575 (40.0)	2.087 (53.0)	0.630 (16)	0.433 (11.0)	1.535 (39)	0.177 (4.5)	1.260 (32.0)	0.446 (11.32)	2.776 (70.5)	1.319 (33.5)	1.457 (37.0)	1.831 (46.5)	0.728 (18.5)	5.38 (8.0)
RF05150VR	5.906 (150)														4.03 (6.0)
RF10150VR	5.906 (150)	2.000 (50.8)	2.638 (67.0)	0.787 (20)	0.551 (14.0)	2.126 (54)	0.248 (6.3)	1.500 (38.1)	0.571 (14.50)	3.661 (93.0)	1.772 (45.0)	1.890 (48.0)	2.319 (58.9)	0.984 (25.0)	8.06 (12)
RF6025VR	6.000 (152.4)	2.252 (57.2)	2.972 (75.5)	0.866 (22)	0.630 (16.0)	2.441 (62)	0.311 (7.9)	1.752 (44.5)	0.626 (15.90)	4.272 (108.5)	2.087 (53.0)	2.185 (55.5)	2.610 (66.3)	1.102 (28.0)	12.1 (18)
RF12200VR	7.874 (200)														10.1 (15)
RF17200VR	7.874 (200)	2.559 (65.0)	3.386 (86.0)	0.984 (25)	0.709 (18.0)	2.717 (69)	0.374 (9.5)	2.000 (50.8)	0.752 (19.10)	5.000 (127.0)	2.382 (60.5)	2.618 (66.5)	2.972 (75.5)	1.220 (31.0)	13.4 (20)

- Engineering Class Chain has steel roller, and is suitable for use from -4°F to +392°F (-20°C to +200°C).
- Engineering Class Chain does not have guide rail.
- Conveying speed of Engineering Class DOUBLE PLUS Chain is approximately 2.3 x chain speed.



## ENGINEERING CLASS

A unique geometry available in 6- or 8-tooth sprockets.

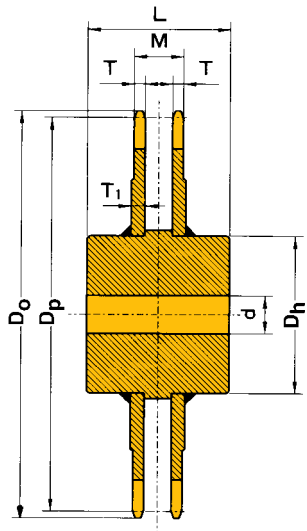

## Sprockets for Engineering Class DOUBLE PLUS® CHAIN

Upper dimensions-inches		Lower dimensions-mm									
Sprocket No.	Number of Teeth	Pitch Dia. $D_p$	Outer Dia. $D_o$	Tooth Thickness T	Tooth Thickness $T_1$	M	Stock Bore Dia. d	Max. Bore	Hub Dia. $D_h$	Hub Length L	Approx. Weight lbs. (kg)
RF03075VR-6T	6	5.906 (150.0)	6.22 (158)	0.20 (5)	0.24 (6)	1.024 (26.0)	0.79 (20)	1.57 (40)	2.56 (65)	2.17 (55)	6.6 (3.0)
RF03075VR-8T	8	7.717 (196.0)	8.23 (209)	0.20 (5)	0.24 (6)	1.024 (26.0)	0.79 (20)	1.77 (45)	2.76 (70)	2.36 (60)	9.9 (4.5)
RF03100VR-6T	6	7.874 (200.0)	8.11 (206)	0.20 (5)	0.24 (6)	1.024 (26.0)	0.79 (20)	1.77 (45)	2.76 (70)	2.36 (60)	9.9 (4.5)
RF03100VR-8T	8	10.287 (261.3)	10.71 (272)	0.20 (5)	0.24 (6)	1.024 (26.0)	0.79 (20)	1.97 (50)	3.15 (80)	2.76 (70)	16.5 (7.5)
RF05100VR-6T	6	7.874 (200.0)	8.07 (205)	0.31 (8)	0.35 (9)	1.398 (35.5)	0.98 (25)	2.36 (60)	3.74 (95)	3.15 (80)	16.5 (7.5)
RF05100VR-8T	8	10.287 (261.3)	10.75 (273)	0.31 (8)	0.35 (9)	1.398 (35.5)	0.98 (25)	2.76 (70)	4.13 (105)	3.54 (90)	28.7 (13)
RF05150VR-6T	6	11.811 (300.0)	11.97 (304)	0.31 (8)	0.35 (9)	1.398 (35.5)	0.98 (25)	2.76 (70)	4.13 (105)	3.54 (90)	33.1 (15)
RF05150VR-8T	8	15.433 (392.0)	15.83 (402)	0.31 (8)	0.35 (9)	1.398 (35.5)	1.18 (30)	2.95 (75)	4.53 (115)	3.94 (100)	52.9 (24)
RF10150VR-6T	6	11.811 (300.0)	12.17 (309)	0.43 (11)	0.47 (12)	1.890 (48.0)	1.18 (30)	3.15 (80)	4.92 (125)	4.13 (105)	44.1 (20)
RF10150VR-8T	8	15.433 (392.0)	16.06 (408)	0.43 (11)	0.47 (12)	1.890 (48.0)	1.38 (35)	3.35 (85)	5.31 (135)	4.53 (115)	70.6 (32)
RF6025VR-6T	6	12.000 (304.8)	12.99 (330)	0.55 (14)	0.63 (16)	2.205 (56.0)	1.38 (35)	3.74 (95)	5.71 (145)	4.92 (125)	64.0 (29)
RF6025VR-8T	8	15.677 (398.2)	17.01 (432)	0.55 (14)	0.63 (16)	2.205 (56.0)	1.38 (35)	3.94 (100)	5.71 (145)	4.92 (125)	92.7 (42)
RF12200VR-6T	6	15.748 (400.0)	17.09 (434)	0.55 (14)	0.63 (16)	2.205 (56.0)	1.38 (35)	3.94 (100)	5.71 (145)	4.92 (125)	94.9 (43)
RF12200VR-8T	8	20.575 (522.6)	21.93 (557)	0.55 (14)	0.63 (16)	2.205 (56.0)	1.57 (40)	4.33 (110)	6.10 (155)	5.31 (135)	147.8 (67)
RF17200VR-6T	6	15.748 (400.0)	17.28 (439)	0.59 (15)	0.63 (16)	2.441 (62.0)	1.57 (40)	4.33 (110)	6.10 (155)	5.31 (135)	103.7 (47)
RF17200VR-8T	8	20.575 (522.6)	22.13 (562)	0.59 (15)	0.63 (16)	2.441 (62.0)	1.77 (45)	4.72 (120)	6.89 (175)	5.91 (150)	167.7 (76)

# Specifications

## PLASTIC RETURN GUIDES AND BRACKETS

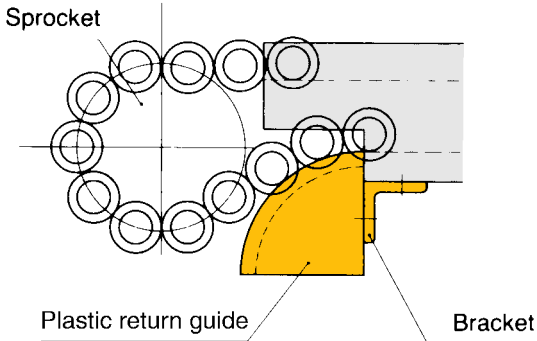

Help maintain low noise levels and ensure a smooth transition.

## PLASTIC RETURN GUIDES

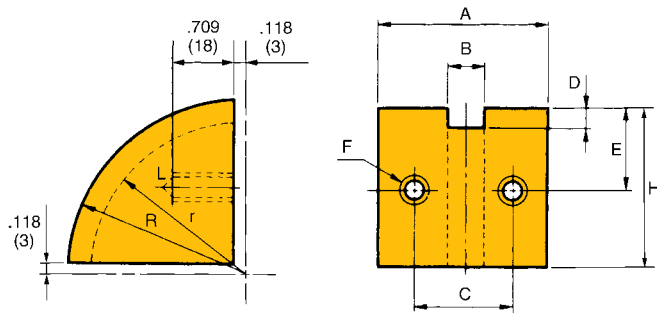

## PLASTIC RETURN GUIDES FOR DOUBLE PLUS® WITH SNAP COVERS

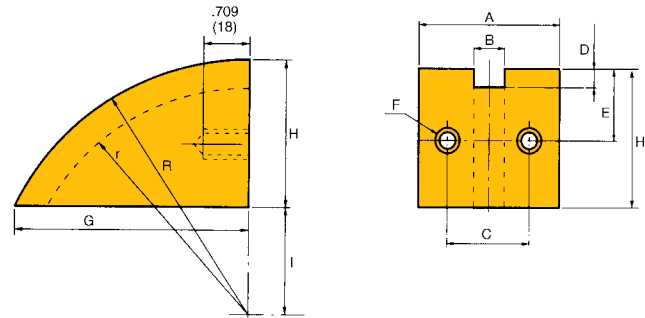

## Plastic Return Guide Dimensional Data

Guide No.	A	B	C	D	E	F	G	H	I	r	R
C2030VRP-RG	1.34 (34)	0.35 (9)	0.87 (22)	0.24 (6.0)	1.22 (31)	M6	—	2.24 (57)	—	2.13 (54.0)	2.36 (60)
C2040VRP-RG	1.97 (50)	0.47 (12)	1.18 (30)	0.31 (8.0)	1.18 (30)	M8	—	2.24 (57)	—	2.05 (52.0)	2.36 (60)
C2050VRP-RG	2.20	0.59	1.38	0.39	1.26	M8	—	2.24 (57)	—	1.97 (50.0)	2.36 (60)
C2050VRP-RG-SC	(56)	(15)	(35)	(10.0)	(32)		3.56 (90.3)	2.24 (57)	1.69 (43)	3.54 (90.0)	3.94 (100)
C2060VRP-RG	2.36	0.71	1.54	0.49	1.26	M8	—	2.24 (57)	—	1.87 (47.5)	2.36 (60)
C2060VRP-RG-SC	(60)	(18)	(39)	(12.5)	(32)		3.56 (90.3)	2.24 (57)	1.69 (43)	3.44 (87.5)	3.94 (100)
C2080VRP-RG	2.76	0.91	1.77	0.59	1.61	M8	—	3.03 (77)	—	2.56 (65.0)	3.15 (80)
C2080VRP-RG-SC	(70)	(23)	(45)	(15.0)	(41)		5.50 (139.6)	3.03 (77)	3.46 (88)	5.91 (150.0)	6.50 (165)

Note: Specify SC type for use with Snap Cover DOUBLE PLUS.  
For chain sizes C2030VRP-SC and C2040VRP-SC, use standard plastic return guide.

## BRACKET

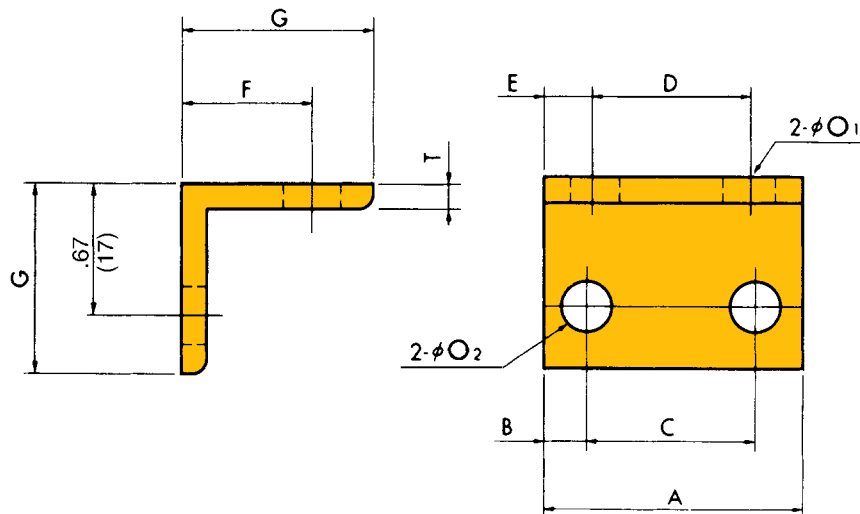

Allow convenient installation of plastic return guides.

## Bracket Dimensional Data

Upper dimensions-inches Lower dimensions-mm											Mounting Bolt Size	
Chain No.	A	B	C	D	E	F	G	O <sub>1</sub>	O <sub>2</sub>	T		
C2030VRP-GB	1.34 (34)	0.236 (6.0)	0.87 (22)	0.807 (20.5)	0.26 (6.7)	0.71 (18)	0.98 (25)	0.256 (6.5)	0.256 (6.5)	0.12 (3)	M6 X 20 ℓ	
C2040VRP-GB	2.36 (60)	0.591 (15.0)	1.18 (30)	1.752 (44.5)	0.30 (7.7)	0.79 (20)	1.18 (30)	0.335 (8.5)	0.335 (8.5)	0.12 (3)		
C2050VRP-GB	2.99 (76)	0.807 (20.5)	1.38 (35)	2.185 (55.5)	0.40 (10.2)	0.94 (24)	1.38 (35)	0.413 (10.5)	0.335 (8.5)	0.16 (4)		M8 X 20 ℓ
C2060VRP-GB	3.70 (94)	1.083 (27.5)	1.54 (39)	2.854 (72.5)	0.42 (10.7)	0.94 (24)	1.38 (35)	0.413 (10.5)	0.335 (8.5)	0.16 (4)		
C2080VRP-GB	3.94 (100)	1.083 (27.5)	1.77 (45)	2.756 (70.0)	0.59 (15.0)	0.94 (24)	1.38 (35)	0.413 (10.5)	0.335 (8.5)	0.16 (4)		

# Specifications

C2040VRP-R4L  
C2050VRP-R4L  
C2060VRP-R4L

C2030VRP-R3L

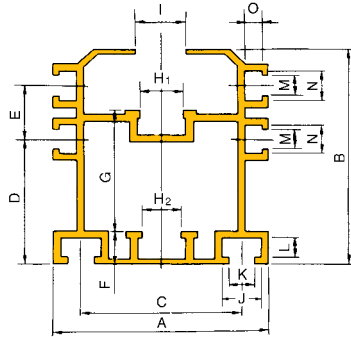
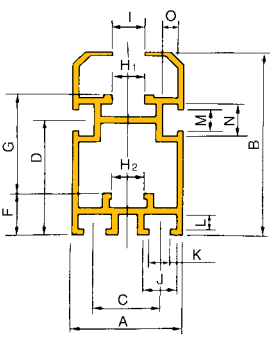

C2050VRP-R3H

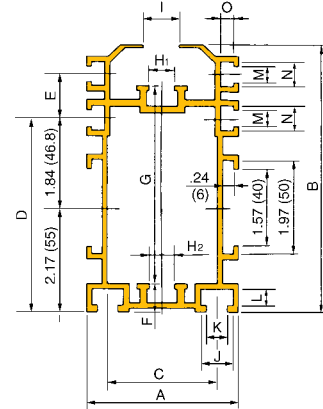

C2060VRP-R4K

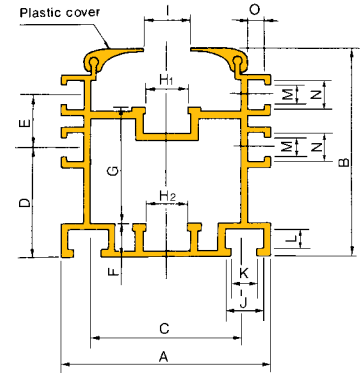

C2040VRP-R3LS  
C2050VRP-R3LS  
C2060VRP-R3LS

C2030VRP-R3LS

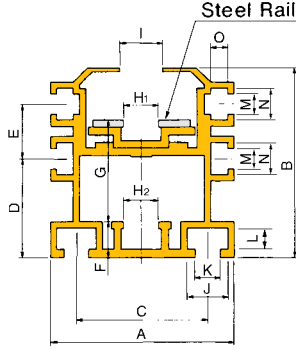
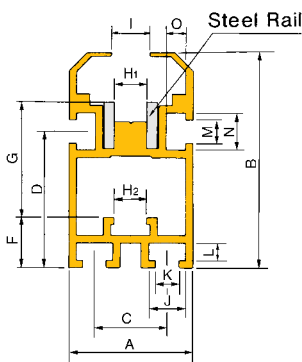

C2050VRP-R3HS

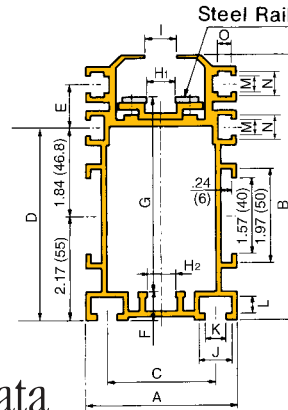

C2080VRP-R3LS

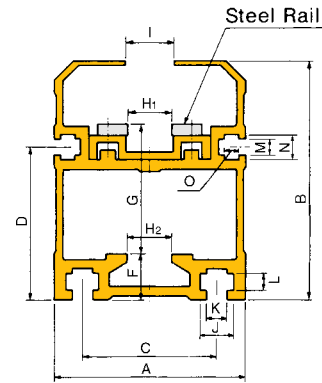

## Aluminum Guide Rail Dimensional Data Standard and Steel Rail Inserts

Upper dimensions-inches																	Standard	Mass
Lower dimensions-mm																	Length	lbs./ft.
Guide Rail No.	A	B	C	D	E	F	G	H <sub>1</sub>	H <sub>2</sub>	I	J	K	L	M	N	O	ft. (m)	(kg/m)
C2030VRP-R3L	1.38	2.36	0.807	1.494	—	0.55	1.268	0.350	0.366	0.390	0.413	0.256	0.197	0.256	0.413	0.197	9.84	0.94
C2030VRP-R3LS	(35)	(60)	(20.5)	(37.95)	—	(14)	(32.2)	(8.9)	(9.3)	(9.9)	(10.5)	(6.5)	(5.0)	(6.5)	(10.5)	(5.0)	(3)	1.48
																		(2.2)
C2040VRP-R4L	2.48	2.60	1.752	1.388	0.728	0.51	1.374	0.449	0.472	0.531	0.531	0.335	0.295	0.256	0.413	0.197	13.12	1.75
C2040VRP-R4LS	(63)	(66)	(44.5)	(35.25)	(18.5)	(13)	(34.9)	(11.4)	(12.0)	(13.5)	(13.5)	(8.5)	(7.5)	(6.5)	(10.5)	(5.0)	(4)	2.49
																		(3.7)
C2050VRP-R4L	3.07	3.15	2.185	1.644			1.693										13.12	2.42
C2050VRP-R4LS	(78)	(80)	(55.5)	(41.75)			(43.0)										(4)	(3.6)
					0.906	0.59		0.56	0.59	0.65	0.689	0.413	0.35	0.335	0.531	0.295		(5.0)
C2050VRP-R3H					(23.0)	(15)		(14.3)	(15)	(16.5)	(17.5)	(10.5)	(9)	(8.5)	(13.5)	(7.5)		3.36
C2050VRP-R3HS	3.15	5.51	2.26	4.01			4.06										9.84	(5.0)
	(80)	(140)	(57.5)	(101.75)			(103)										(3)	4.23
																		(6.3)
C2060VRP-R4L				2.018														2.82
C2060VRP-R4LS	3.74	3.58	2.854	(51.25)	0.925	0.59	1.988	0.677	0.709	0.768	0.689	0.413	0.354	0.335	0.531	0.295	13.12	(4.2)
	(95)	(91)	(72.5)		(23.5)	(15)	(50.5)	(17.2)	(18.0)	(19.5)	(17.5)	(10.5)	(9.0)	(8.5)	(13.5)	(7.5)	(4)	3.96
																		(5.9)
C2060VRP-R4K				1.821														2.69
				(46.25)														(4.0)
C2080VRP-R3LS	3.94	4.92	2.76	3.15	0.47	0.94	2.68	0.91	0.91	0.98	0.689	0.413	0.35	0.335	0.531	0.295	9.84	6.65
	(100)	(125)	(70)	(80)	(12)	(24)	(68)	(23)	(23)	(25)	(17.5)	(10.5)	(9)	(8.5)	(13.5)	(7.5)	(3)	(9.9)

Note: The steel rail is fixed to the frame with bolts.

**C2030VRP-PGR**

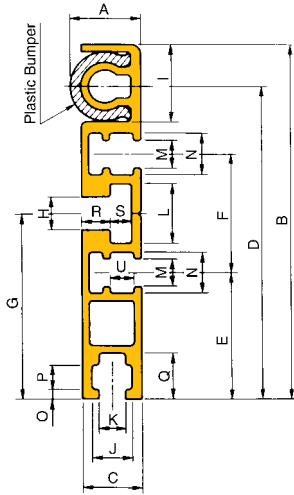

**C2040VRP-PGR**

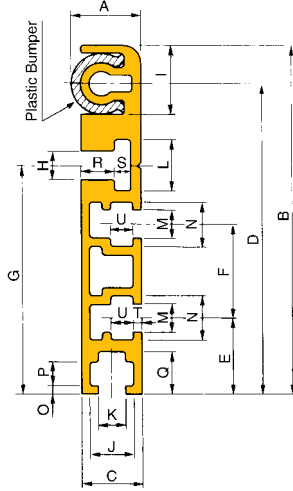

**C2050VRP-PGR**

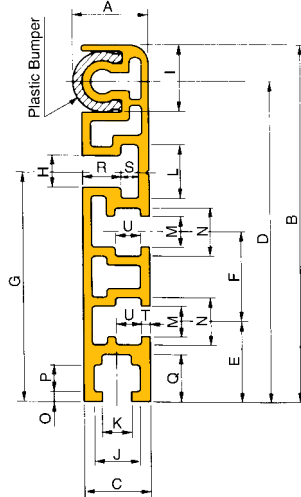

**C2060VRP-PGR**

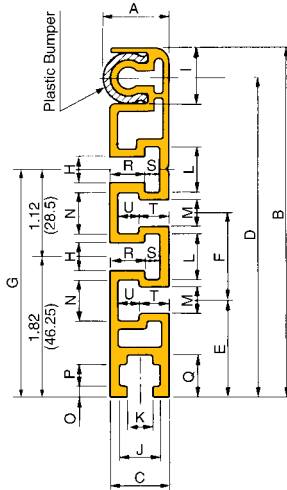

**C2080VRP-PGR**

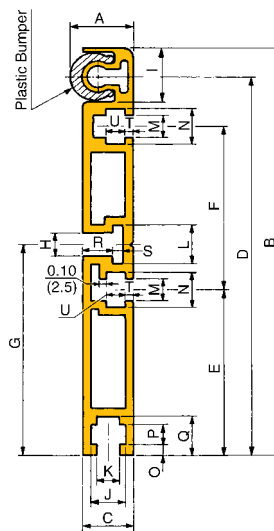

Protect your products by keeping them securely on the system.

## Pallet Guide Rail Dimensional Data

	Upper dimensions-inches																			Standard Length	Mass lbs/ft		
	Lower dimensions-mm																					ft. (m)	(kg/m)
	A	B	C	D	E	F	G	H	I	J	K	L	M	N	O	P	Q	R	S	T	U		
C2030VRP-PGR	0.60 (15.3)	2.89 (73.5)	0.49 (12.5)	2.51 (63.8)	1.02 (26)	0.94 (24)	1.50 (38)	0.28 (7)	0.70 (17.9)	0.33 (8.5)	0.22 (5.5)	0.47 (12)	0.22 (5.5)	0.33 (8.5)	0.08 (2)	0.20 (5)	0.37 (9.5)	0.18 (4.5)	0.24 (6)	—	0.20 (5)	9.84 (3)	0.6 (0.9)
C2040VRP-PGR	0.68 (17.3)	3.27 (83)	0.57 (14.5)	2.88 (73.1)	0.71 (18)	0.87 (22)	2.12 (53.75)	0.28 (7)	0.71 (18.15)	0.41 (10.5)	0.26 (6.5)	0.47 (12)	0.26 (6.5)	0.41 (10.5)	0.08 (2)	0.22 (5.5)	0.39 (10)	0.26 (6.5)	0.22 (5.5)	0.08 (2)	0.22 (5.5)	13.12 (4)	1.0 (1.5)
C2050VRP-PGR	0.88 (22.3)	3.94 (100)	0.77 (19.5)	3.50 (88.8)	0.91 (23)	0.98 (25)	2.55 (64.8)	0.35 (9)	0.81 (20.7)	0.53 (13.5)	0.33 (8.5)	0.59 (15)	0.33 (8.5)	0.53 (13.5)	0.12 (3)	0.30 (7.5)	0.53 (13.5)	0.45 (11.5)	0.20 (5)	0.10 (2.5)	0.30 (7.5)	13.12 (4)	1.5 (2.2)
C2060VRP-PGR	0.88 (22.3)	4.57 (116)	0.77 (19.5)	4.13 (104.9)	1.26 (32)	1.12 (28.5)	2.94 (74.75)	0.35 (9)	0.81 (20.6)	0.53 (13.5)	0.33 (8.5)	0.59 (15)	0.33 (8.5)	0.53 (13.5)	0.14 (3.5)	0.30 (7.5)	0.55 (14)	0.45 (11.5)	0.20 (5)	0.39 (10)	0.28 (7)	13.12 (4)	1.7 (2.5)
C2080VRP-PGR	0.88 (22.3)	6.10 (155)	0.77 (19.5)	5.67 (144)	2.46 (62.5)	2.46 (62.5)	3.15 (80)	0.35 (9)	0.81 (20.5)	0.53 (13.5)	0.33 (8.5)	0.59 (15)	0.33 (8.5)	0.53 (13.5)	0.16 (4)	0.30 (7.5)	0.57 (14.5)	0.45 (11.5)	0.16 (4)	0.12 (3)	0.30 (7.5)	9.84 (3)	2.4 (3.5)

# Selection Guidelines

## I. Confirm operating conditions for DOUBLE PLUS® conveyor.

The following information is needed to select the appropriate chain:

- Material, weight, dimension, and quantity of the conveyed object (including pallet)
- Conveyor speed
- Conveyor length (the length for accumulating and transferring section respectively)
- Lubrication requirements and environment

## II. Select initial chain size.

The proper selection of DOUBLE PLUS Chain considers the vertical force exerted on the rollers, as well as the tension on the chain due to friction that results. Make initial chain selection based on maximum allowable chain tension. (See Table 1a or 1b.)

$$T_T = W_T \times f \times K$$

$T_T$ : Total chain(s) tension (kgf or lbs.)

$W_T$ : Total weight of conveyed object except chain (kg or lbs.)

$f$ : Coefficient of friction  $f=f_2+f_3$  (See Table 2.)

$K$ : Chain speed coefficient (See Table 3.)

*Note: If two strands of chain are used, multiply  $T_T$  by 0.6 to find tension per strand.*

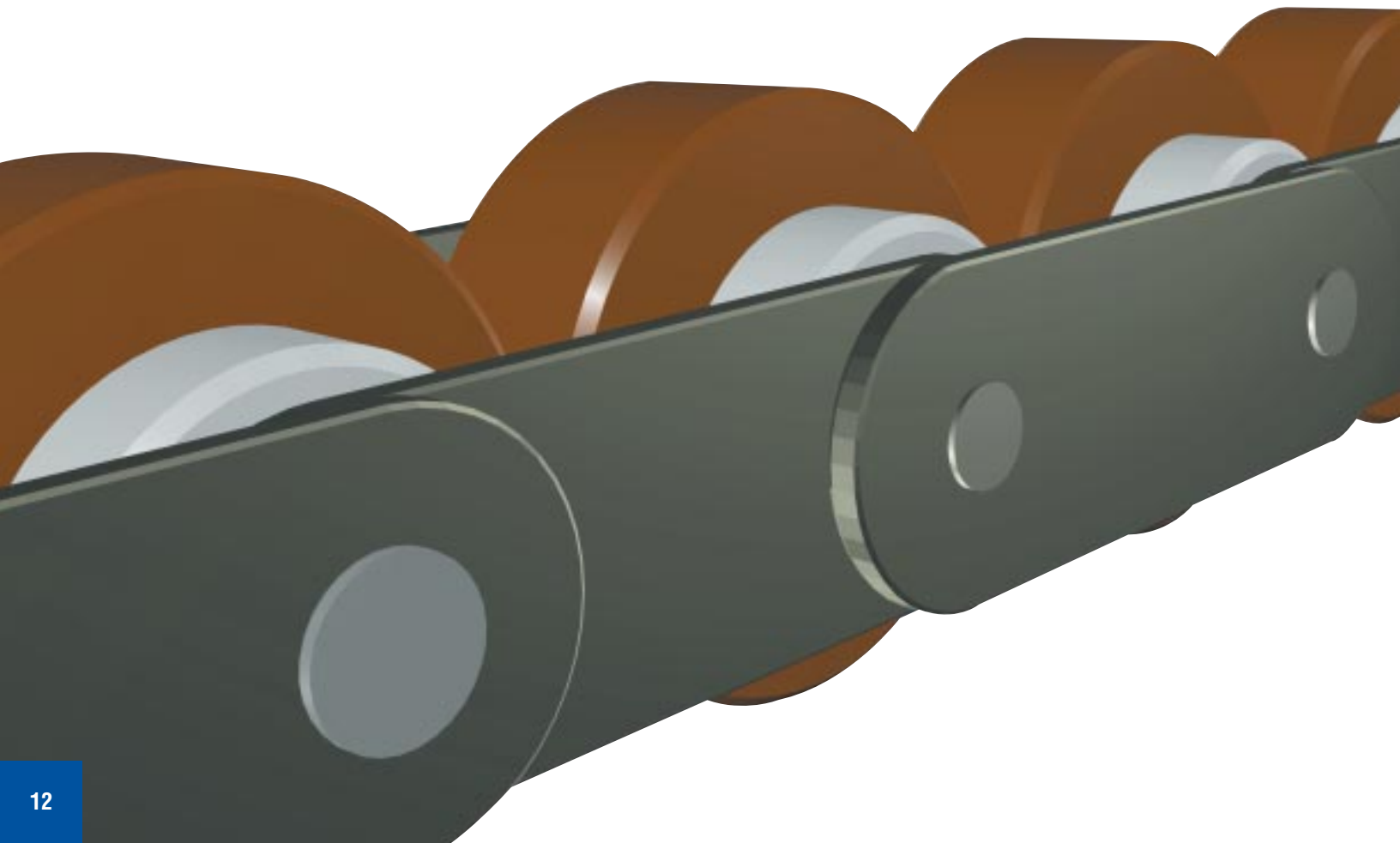



Table 1a. Maximum Allowable Chain Tension  
Standard and DOUBLE PLUS® Chain  
with Snap Covers

Units-lbs. (kgf)	Chain No.				
	C2030	C2040	C2050	C2060	C2080
Regular Plastic	120 (56)	200 (90)	310 (140)	460 (210)	1,190 (540)
High-Friction Plastic	60 (28)	100 (45)	155 (70)	230 (105)	595 (270)
Stainless Steel	60 (28)	100 (45)	155 (70)	230 (105)	595 (270)
Steel	220 (100)	350 (160)	550 (250)	840 (380)	— —

Note: These factors are for your reference only.

Table 1b. Maximum Allowable Chain Tension  
Engineering Class DOUBLE PLUS® Chain

Units-lbs. (kgf)	Maximum Allowable Chain Tension
Chain No.	
RF03075VR	930
RF03100VR	(420)
RF05100VR	2,200
RF05150VR	(1,000)
RF10150VR	3,530
	(1,600)
RF6025VR	5,950
RF12200VR	(2,700)
RF17200VR	7,720
	(3,500)

Note: These factors are for your reference only.

Table 2. Coefficient of Friction for DOUBLE PLUS® Chains

Coefficient of Friction	TYPE OF DOUBLE PLUS CHAIN					
	Plastic Roller		Steel Roller		Engineering Class	
	Standard	High-Friction	Lubricated	Nonlubricated	Lubricated	Nonlubricated
Coefficient of friction $f_1$ between chain and rail when conveying	0.08	0.08	0.05	0.05	0.05	0.05
Coefficient of friction $f_2$ between chain and conveyed object when accumulating	0.10	0.15	0.10	0.15	0.10	0.15
Coefficient of friction $f_3$ between chain and rail when accumulating	0.20	0.25	0.10	0.25	0.15	0.20

Note: These factors are for your reference only.  
We suggest oiling steel roller type.

Table 3. Chain Speed Coefficient

Chain Speed ft./min. (m/min)	Chain Speed Coefficient (K)
0~50 (0~15)	1.0
50~100 (15~30)	1.2

Note: These factors are for your reference only.  
For speeds greater than those indicated, consult U.S. Tsubaki.

# Selection Guidelines

## III. Confirm the maximum allowable roller load.

The roller load due to conveyed objects (see Fig. 1) should not exceed the values shown in Table 4a or 4b (Table depends on product used.)

Figure 1—Conveyed object weight per roller

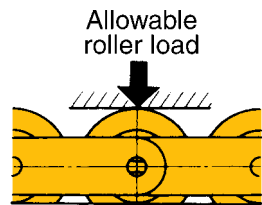

DOUBLE PLUS® Chain

Table 4a. Maximum Allowable Roller Load\* Standard and DOUBLE PLUS® Chain with Snap Covers

Chain No.	Units-lbs./ft. (kgf/m)		
	Plastic Roller Aluminum Guide Rail	Plastic Roller Aluminum Frame with Steel Rail	Steel Roller
C2030	27 (40)	54 (80)	108 (160)
C2040	40 (60)	81 (120)	161 (240)
C2050	54 (80)	108 (160)	215 (320)
C2060	67 (100)	134 (200)	269 (400)
C2080	— —	202 (300)	— —

Note: These factors are for your reference only.  
\*This is the load for two strands of DOUBLE PLUS® Chain

Table 4b. Maximum Allowable Roller Load Engineering Class DOUBLE PLUS® Chain

Chain No.	Maximum Allowable Roller Load
RF03075VR	290
RF03100VR	(130)
RF05100VR	530
RF05150VR	(240)
RF10150VR	770
	(350)
RF6025VR	1,100
RF12200VR	(500)
RF17200VR	1,370
	(620)

Note: These factors are for your reference only.

## IV. Confirm total chain tension (T<sub>T</sub>).

In general, a DOUBLE PLUS® system uses two strands of chain. When calculating the total chain tension (T<sub>T</sub>), be sure to include the weight of each strand. The chain tension (T<sub>T</sub>) is calculated using the following formula:

Figure 2—Distribution of product line

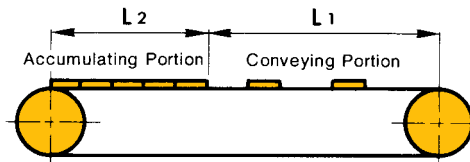

$$T_T = (W_1 + M) L_1 \times f_1 + W_2 \times L_2 \times f_2 + (W_2 + M) L_2 \times f_3 + 1.1 M (L_1 + L_2) f_1$$

$0.6 \times T_T \times K \leq$  Maximum allowable chain tension (Table 1a or 1b)

- T<sub>T</sub>: Total chain tension (lbs. or kgf)
- T<sub>s</sub>: Chain Tension/Strand (lbs. or kgf)
- W<sub>1</sub>: Weight of conveyed objects in conveying portion (lbs./ft. or kg/m)
- W<sub>2</sub>: Weight of conveyed objects in accumulating portion (lbs./ft. or kg/m)
- M: Weight of chain and slat, etc. (lbs./ft. or kg/m)
- L<sub>1</sub>: Length of conveying portion (ft. or m)
- L<sub>2</sub>: Length of accumulating portion (ft. or m)
- f<sub>1</sub>: Coefficient of friction between chain and rail when conveying
- f<sub>2</sub>: Coefficient of friction between chain and conveyed object when accumulating
- f<sub>3</sub>: Coefficient of friction between chain and rail when accumulating
- HP: Required horsepower
- kW: Required kilowatts
- V: Chain speed (ft./min. or m/min.)
- η: Transmission efficiency of drive unit

Note: When there are two strands in parallel, the maximum chain tension should be  $T_s = 0.6 \times T_T$ .

## V. Calculate required power.

$$HP = \frac{T_T \times V \times 1.1}{33,000\eta} \quad \text{or} \quad kW = \frac{T_T \times V \times 1.1}{6,120\eta}$$

## Selection Procedure Example.

### i) Confirm operating conditions for DOUBLE PLUS® conveyor.

Conveyor length: 30 ft. (9.14 m)  
 Dimensions of conveyed object: 1.5 ft. (0.46 m) square  
 Weight of conveyed object: 53 lbs. (24 kg)/piece  
 $53 \text{ lbs./piece} \div 1.5 \text{ ft.} = 35.3 \text{ lbs./ft. (52.6 kg/m)}$   
 Conveyed product speed: 30 ft./min (9.14 m/min).  
 Chain speed: 12 ft./min. (3.66 m/min.)  
 Full conveyor accumulating  
 Quantity of conveyed object: 20 pieces  
 Dry, in-plant use, normal operating temps (up to 77°F)

### ii) Select initial chain size.

Using the calculation method in Section II. on page 12:

$$T_T = W_T \times (f_2 + f_3) \times K$$

$$T_T = (35.3 \text{ lbs./ft.} \times 30 \text{ ft.}) \times (0.1 + 0.2) \times 1.0 = 318 \text{ lbs. (144 kgf)}$$

$$T_S = 318 \text{ lbs.} \times 0.6 = 190.8 \text{ lbs (86.5 kgf)}$$

*Note: Presume two strands of chain, each loaded by 0.6 of the total.*

Based on these calculations, C2040VRP-A chain is the preliminary choice, but this selection must be confirmed.

*Note: C2040VRP-A weight/ft. = 0.67 lbs./ft. (1.0 kg/m) per strand [1.34 lbs./ft. (2.0 kg/m) for two strands].*

### iii) Confirm the maximum allowable roller load.

By consulting Table 4a or 4b, you find that for C2040VRP-A, the maximum allowable roller load is 40 lbs./ft. (60 kg/m) for aluminum rail.

In this example, the weight of the conveyed object is 35.3 lbs./ft. (52.6 kg/m). Therefore, C2040VRP-A can cover roller load.

### iv) Confirm total chain tension.

Using the calculation method of total chain tension ( $T_T$ ):

$$T_T = (0 + 1.34) \times 0 \times 0.08 + 35.3 \times 30 \times 0.10 + (35.3 + 1.34) \times 30 \times 0.20 + 1.1 \times 1.34 \times (0 + 30) \times 0.08$$

$$T_T = 329 \text{ lbs. (149 kgf)}$$

$$T_S = T_T \times 0.6 = 197 \text{ lbs. (89 kgf) per strand}$$

### Now determine chain size.

Multiply the chain tension ( $T_S$ ) by the chain speed coefficient (K) listed in Table 3, confirm with the following formula:

$$T_S \times K \leq \text{Maximum allowable chain tension (Table 1a or 1b).}$$

$$197 \times 1.0 \leq 200 \text{ (C2040VRP regular plastic)}$$

In this example, we would choose C2040VRP-A Chain.

### v) Calculate required power.

\*Presume gearmotor efficiency ( $\eta$ ) = 0.8

$$\text{HP} = \frac{329 \text{ lbs.} \times 12 \text{ ft./min.} \times 1.1}{33,000 \times 0.8} = 0.17 = 1/4 \text{ HP motor}$$

$$\text{kW} = \frac{149 \text{ kgf} \times 3.66 \text{ m/min.} \times 1.1}{6,120 \times 0.8} = .13 \text{ kW} = 0.2 \text{ kW motor}$$

- This calculation sample is for your reference only.

# Design Guidelines

## I. Dimensions for both ends of the conveyor.

A typical arrangement of DOUBLE PLUS® components is illustrated in Fig. 3. The bracket is used to mount the plastic return guide to the aluminum guide rail, allowing the chain to flow smoothly between the sprocket and guide rail. See Table 5a for dimensions.

Figure 3—Typical arrangement of DOUBLE PLUS® components

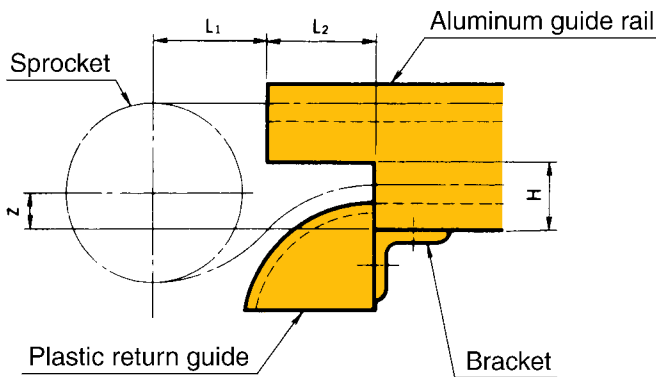

Table 5a. Conveyor End Dimensions

Units-in. (mm)					
Chain No.	Z	L <sub>1</sub>	L <sub>2</sub> (Driver side)	L <sub>2</sub> (Driven side)	H
C2030VRP-R3L	0.839	1.57	8.27	3.15	0.98
C2030VRP-R3LS	(21.3)	(40)	(210)	(80)	(25)
C2040VRP-R4L	0.579	1.97	11.81	3.94	0.98
C2040VRP-R4LS	(14.7)	(50)	(300)	(100)	(25)
C2050VRP-R4L	0.634				
C2050VRP-R4LS	(16.1)	2.36	13.39	4.72	1.18
C2050VRP-R3H	3.000	(60)	(340)	(120)	(30)
C2050VRP-R3HS	(76.2)				
C2060VRP-R4K	0.587	2.76	16.93	5.12	1.57
C2060VRP-R4LS	(14.9)	(70)	(430)	(130)	(40)
C2080VRP-R3LS	0.945	3.94	21.65	7.87	2.36
	(24)	(100)	(550)	(200)	(60)

## II. Screws, bolts, height of conveyor.

The values for L shown in Table 5b and Fig. 4 vary because of the plastic bumper wall thickness tolerance.

### Connecting the aluminum guide rail

Connect the aluminum guide rails by aligning the V groove shown by arrow A in Fig. 4.

### Installing the pallet guide rail

Drill holes using the V groove as a guide, shown by arrow B in Fig. 4, and install the pallet guide rail using socket head cap screws from Table 5b.

Figure 4—Location of screws, bolts

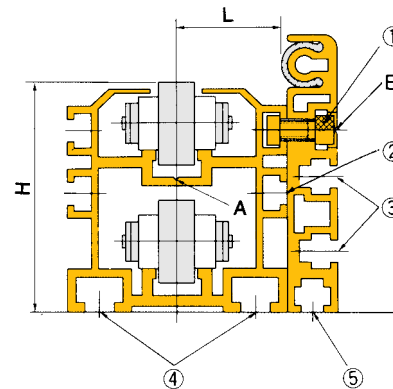

Table 5b. Screws, Bolts, Height of Conveyor

Units-in. (mm)							
Rail No.	1	2	3	4	5	H	L
C2030VRP-R3L	M6 x 10 ℓ	M6	M5	M6	M5	2.42	0.57
C2030VRP-R3LS						(61.5)	(14.5)
C2040VRP-R4L	M6 x 12 ℓ	M6	M6	M8	M6	2.68	1.12
C2040VRP-R4LS						(68)	(28.5)
C2050VRP-R4L	M8 x 20 ℓ	M8	M8	M10	M8	3.25	1.42
C2050VRP-R4LS						(82.5)	(36)
C2050VRP-R3H	M8 x 20 ℓ	M8	M8	M10	M8	5.61	1.46
C2050VRP-R3HS						(142.5)	(37)
C2060VRP-R4K							
C2060VRP-R4L	M8 x 20 ℓ	M8	M8	M10	M8	3.74	1.75
C2060VRP-R4LS						(95)	(44.5)
C2080VRP-R3LS	M8 x 25 ℓ	M8	M8	M10	M8	5.12	1.85
						(130)	(47)

### III. Nominal spacing of conveyor supports.

Proper operation of DOUBLE PLUS® Chain is maintained by controlling the amount of deflection of the aluminum guide rail. This deflection is determined from the weight of the conveyed goods and the second moment of area, shown in Table 5c. To control deflection, supports should be spaced as shown in Fig. 5, in accordance with the following equation:

#### Determining support spacing

$$\ell \text{ (in.)} = \frac{[384 \times E \times I \times \delta \times 12]^{1/4}}{5 \times 0.6 \times W}$$

$$\ell \text{ (mm)} = \frac{[384 \times E \times I \times \delta \times 10^3]^{1/4}}{5 \times 0.6 \times W}$$

$\ell$  = spacing support (inches or mm)

E = Young's Modulus = 9.956 x 10<sup>6</sup> lbs./in. (7.0 x 10<sup>3</sup> kg/mm<sup>2</sup>)

I = Second moment of area = in.<sup>4</sup> (cm<sup>4</sup>) (See Table 5c.)

$\delta$  = Deflection = 0.079 in. (2mm)

W = Total conveyed weight = lbs./ft. (kg/m)

*Note: The total conveyed weight (W) is not always distributed evenly between the two conveyor strands. This is taken into account with the factor 0.6.*

Figure 5—Nominal spacing of conveyor supports ( $\ell$ )

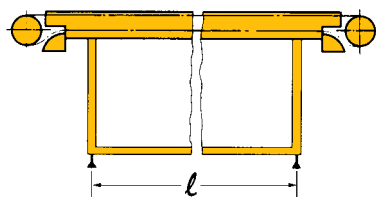

Table 5c. Second Moment of Area

Units- in. <sup>4</sup> (cm <sup>4</sup> )	Rail No.	Second moment of area (I) in. <sup>4</sup> (cm <sup>4</sup> )
Aluminum Guide Rail	C2030VRP-R3L	0.41148 (17.127)
	C2040VRP-R4L	0.96545 (40.185)
	C2050VRP-R4L	2.01905 (84.039)
	C2050VRP-R3H	9.80904 (408.283)
	C2060VRP-R4L	3.24668 (135.137)
	C2060VRP-R4K	2.60692 (108.508)
Aluminum Frame with Steel Rail	C2030VRP-R3LS	0.42815 (17.821)
	C2040VRP-R4LS	1.06460 (44.312)
	C2050VRP-R4LS	2.29735 (95.623)
	C2050VRP-R3HS	10.62133 (442.093)
	C2060VRP-R4LS	4.12657 (171.761)
	C2080VRP-R3LS	8.66648 (360.726)

### IV. Finishing the ends of the conveying side.

Put a chamfer on the ends of the upper rail that the chain's small rollers travel on (Fig. 6).

Figure 6—Location of Chamfer

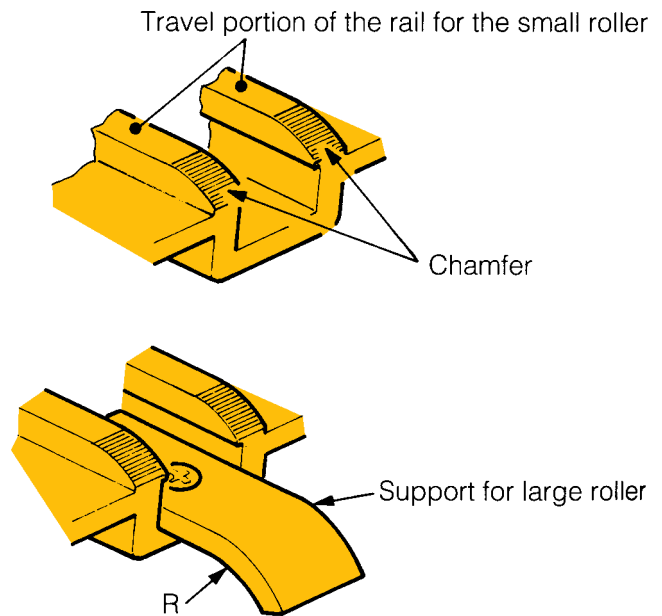

It is possible to prevent the chain's large roller from dipping at the chamfered portion by installing a support for the large roller on the ends of the rail on the driven side.

### V. Aluminum frame with steel rail.

(1) Two basic constructions are used when building guide rail with aluminum frame and steel rail:

For C2030VRP-R3LS, a steel rail (no. 3) is arranged in the vertical position and lock screws (no. 4) are secured into the frame (no. 1) from both sides (see Fig. 7a). See Table 5d for dimensions and hardware.

Figure 7a—Cross section of C2030VRP-R3LS

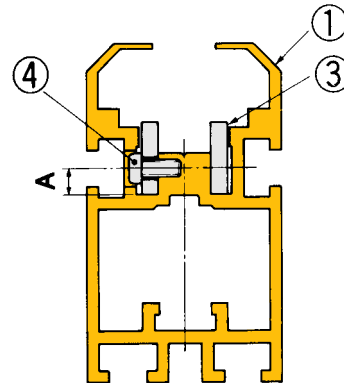

# Design Guidelines

Lock screws (no. 4) are secured through the inner rail (no. 2), which anchors the steel rail (no. 3) to the frame (no. 1) (see Fig. 7b). See Table 5d for dimensions and hardware.

Figure 7b—Cross section of C2040VRP-C2080VRP frame with steel rail

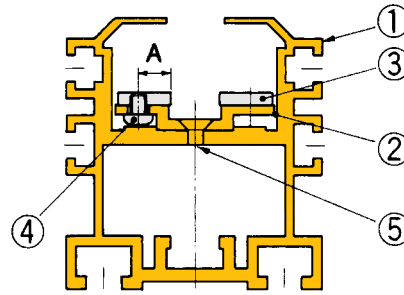

Table 5d. Aluminum Frame with Steel Rail

Units-in. (mm)	Steel rail (Part No. 3)		Installation screws for steel rail (Part No. 4). philips pan head machine screws	Installation screws for steel rail (Part No. 5). philips flat head machine screws
	Dimensions (Plate thickness x width) in. (mm)	"A" dimension in. (mm)		
Rail No.				
C2030VRP-R3LS	.12 x .51 (3 x 13)	.187 (4.75)	M3 x 7 ℓ	—
C2040VRP-R4LS	.12 x .51 (3 x 13)	.315 (8.0)	M4 x 5 ℓ	M4 x 6 ℓ
C2050VRP-R4LS	.12 x .51 (3 x 13)	.315 (8.0)	M4 x 6 ℓ	M4 x 6 ℓ
C2050VRP-R3HS	.12 x .51 (3 x 13)	.315 (8.0)	M4 x 6 ℓ	M4 x 6 ℓ
C2060VRP-R4LS	.12 x .51 (3 x 13)	.315 (8.0)	M4 x 6 ℓ	M4 x 6 ℓ
C2080VRP-R3LS	.24 x .63 (6 x 16)	.413 (10.5)	M5 x 8 ℓ	M6 x 10 ℓ

## (2) Assembly drawing

When joining rail sections to form a longer conveyor, please refer to Fig. 8.

Figure 8—Assembly Drawing

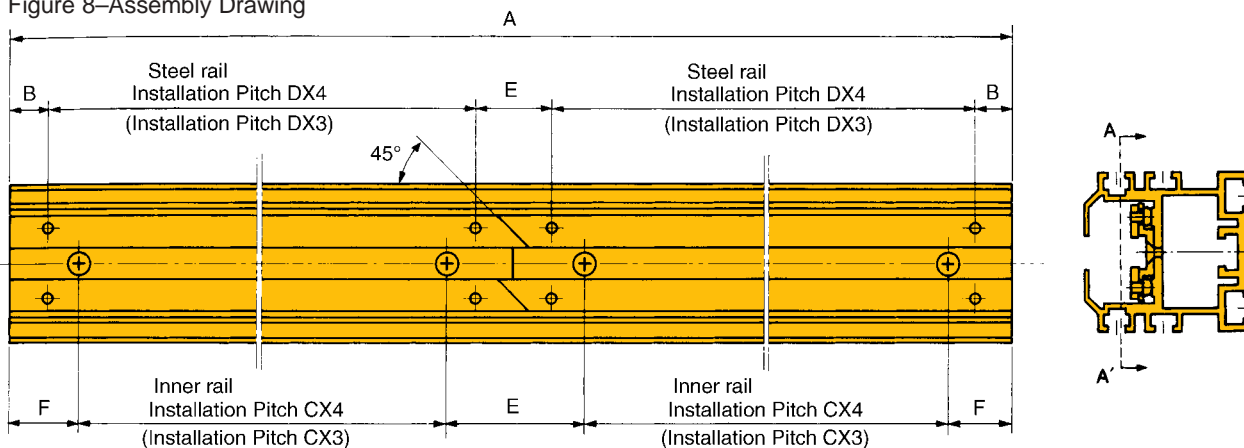

- 1) The steel rail is cut at an angle of 45° at the center portion of the main rail.
- 2) The installation spacing for C2030VRP-R3LS steel rail is the same as that for C2050VRP-R3HS and C2080VRP-R3LS.

Table 5e. Steel Rail Assembly Dimensions

Units-in. (mm)	A	B	C	D	E	F
Rail No.						
C2040VRP-R4LS						
C2050VRP-R4LS	157.5	1.18	19.09			
C2060VRP-R4LS	(4000)	(30)	(485)	19.09	2.36	1.18
C2050VRP-R3LS	118.1	0.59	18.90	(485)	(60)	(30)
C2080VRP-R3LS	(3000)	(15)	(480)			



### (3) Important points when handling steel guide rail

- **When cutting the guide rail with steel rail**

- 1) Cut anywhere other than the central portion or screwed portions of the rail.
- 2) Remove burrs, etc., that occur on the cut surface.
- 3) Insert lock screws into the steel rail and inner rail along with the inner rail and main rail at 0.6 - 1.2 in. (15 - 30 mm) from the cut end.
- 4) Machine all parts individually.
- 5) Completely remove all burrs before reassembly.

*Note: Use screws according to Table 5d when reassembling the conveyor.*

- **When connecting the rail**

After connecting the rail, put small chamfers on the mating faces of the steel rail where steps occur (in both vertical and lateral directions). These prevent the chain rollers from getting caught at these areas.

### VI. Transferring objects between conveyors.

To convey pallets in a stable condition at the transfer portion of the conveyor, install a roller between the two conveyors or the shafts of the sprockets (see Fig. 9). Be sure that the distance  $\ell$  from the ends of the rail to the roller that supports the pallets is less than 1/2.5 times the pallet length in the conveying direction.

Figure 9—Install a roller as shown for a straight line transfer

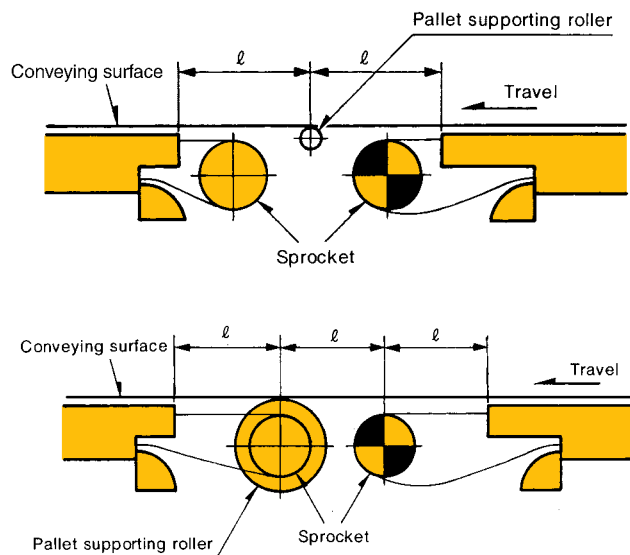

### VII. Take-up.

The amount of take-up  $\ell = (L \times 0.02) + \text{marginal length}$   
 (0.02 = Allowable chain wear elongation 2%)

Allow for some sagging (up to 10% of the span) in the chain on the bottom of the driver sprocket. Adjust the take-up so that the slack does not exceed the values in Table 5f. (see Fig. 10.) In addition, the total arc of contact between the chain and sprocket should be more than 130°. If take-up cannot be set up as shown in Fig. 11 due to space limitations, refer to Fig. 12.

Table 5f. Chain Slack for DOUBLE PLUS®

Chain size	Normal slack in. (mm)	Maximum slack in. (mm)
C2030	.10 (25)	2.95 (75)
C2040	1.38 (35)	4.13 (105)
C2050	1.57 (40)	4.72 (120)
C2060	1.97 (50)	5.90 (150)
C2080	2.56 (65)	7.48 (190)

Figure 10—Slack tolerance

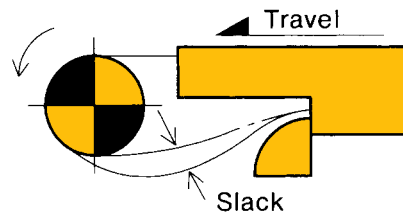
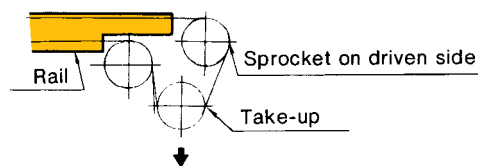

Figure 11—Take-up arrangement



Figure 12—Take-up arrangement for limited space



# Design Guidelines



## VIII. Sprocket and shaft.

Driver sprockets should be keyed, with both left and right sprockets matched in phase.

Take-up sprockets should be keyless, with separate shafts on left and right. Other sprockets should not be keyed.

## IX. Maximum conveyor length.

DOUBLE PLUS® Chain operates well on conveyors with lengths not exceeding 50 ft. (15 m). When conveyor distances are greater than 50 ft. (15 m), make several shorter conveyors in line. If you require one continuous system longer than 50 ft. (15 m), consult U.S. Tsubaki.

## X. For DOUBLE PLUS® Chain with Snap Covers.

When using the arrangement as shown in Fig. 13, be aware that the sprocket cannot engage the chain from the top surface of the snap covers. When bending the chain toward the snap cover side, do not bend beyond the R dimension of the plastic return guide (see page 8). Snap covers and installation are shown in Figs. 14 and 15.

Figure 13—Take-up arrangement for limited space for DOUBLE PLUS® with Snap Covers

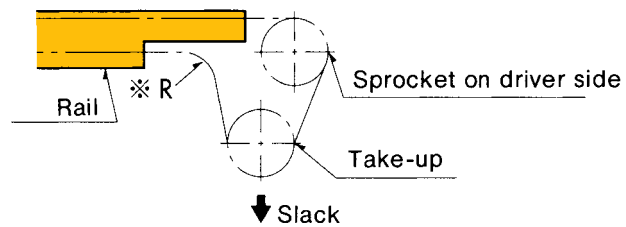

Figure 14—Snap covers for outer and inner links

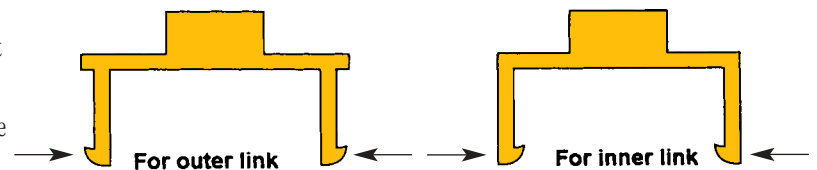

Figure 15—Proper installation of snap covers



# Maintenance Guidelines

DOUBLE PLUS with plastic rollers is designed to operate in a dry environment without contamination from water or oil. Otherwise, the start-up function of the chain will be minimized or eliminated, making conveying difficult.

Transfer product onto DOUBLE PLUS chain smoothly, and avoid dropping heavy product onto the chain.

DOUBLE PLUS with plastic rollers is designed to operate without lubrication.

- If the chain begins to make noise in the sprocket area because of a lack of oil, lubrication may be applied carefully, at the space between the link plates (see Fig. 16). If oil gets on plastic rollers, clean them immediately.

- Steel roller DOUBLE PLUS requires lubrication. Use SAE 10 ~ 20. (For Engineering Class DOUBLE PLUS chain use SAE 30 ~ 40).

Figure 16—Lubricating DOUBLE PLUS® chain

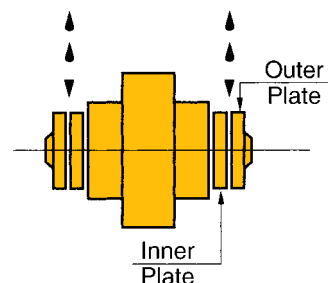

Apply DOUBLE PLUS<sup>®</sup> Technology

- Accumulating conveyors
- Assembly lines
- Cooling and drying operations
- Inspection lines
- And much more!

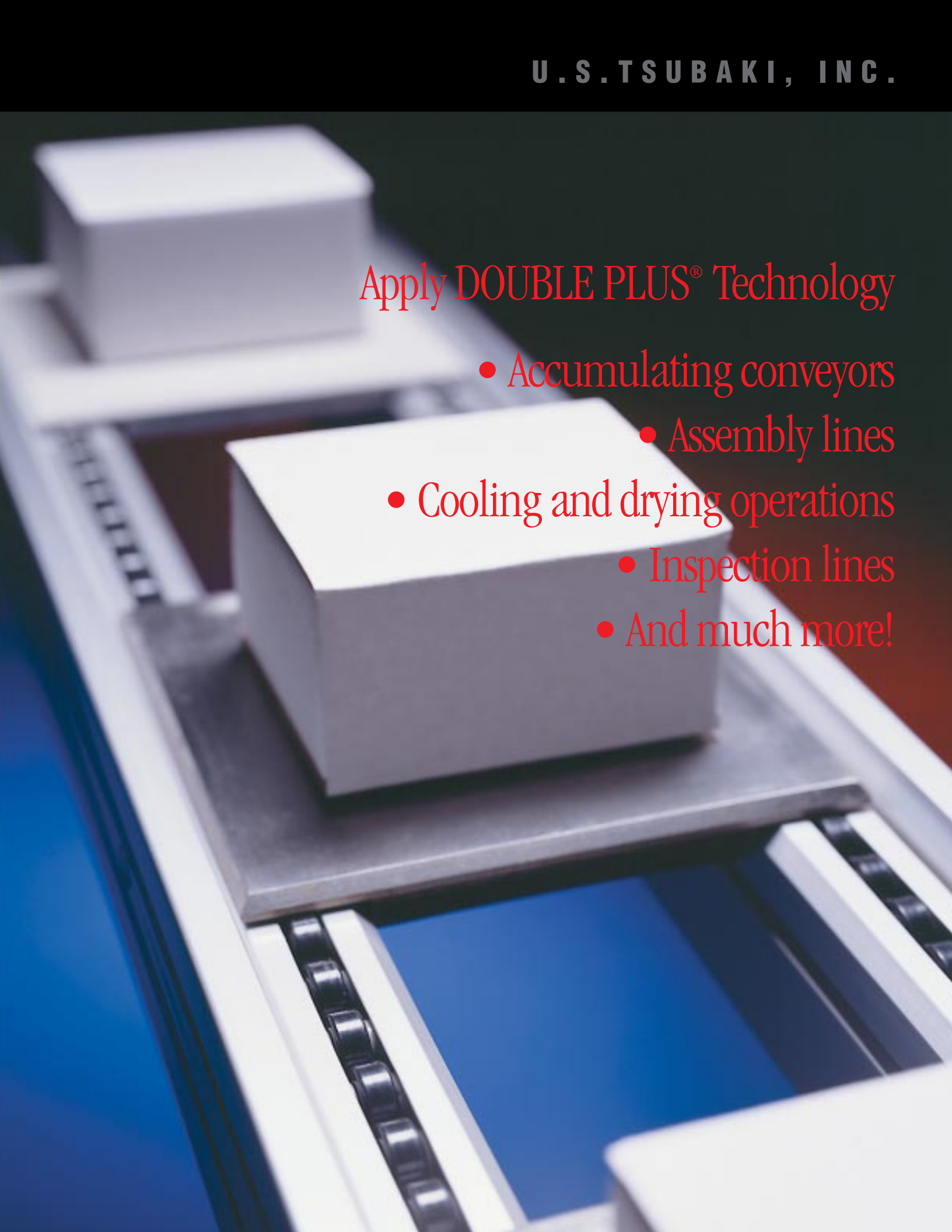

# DOUBLE PLUS<sup>®</sup> Chain and Sprockets

Conveying and Accumulating

**PLUS: Increased Output**  
**PLUS: Reduced Operating Costs**



**U.S. TSUBAKI, INC.**  
**HEADQUARTERS**  
**301 E. MARQUARDT DRIVE**  
**WHEELING, IL 60090**  
**TEL: (800) 323-7790**  
**TEL: (847) 459-9500**  
**FAX: (847) 459-9515**  
**WEB SITE: [www.ustsubaki.com](http://www.ustsubaki.com)**

## Service Centers

**Atlanta, GA**  
**U.S. Tsubaki, Inc.**  
675 Wesleyan Drive, S.W.  
Atlanta, GA 30336  
Tel: (800) 443-8212  
Tel: (404) 349-7973  
Fax: (404) 349-7975

**Charlotte, NC**  
**B.C. & H. Company**  
11010 Monroe Road  
Matthews, NC 28105  
Tel: (704) 847-9131  
Fax: (704) 847-3651

**Chicago, IL**  
**U.S. Tsubaki, Inc.**  
301 E. Marquardt Drive  
Wheeling, IL 60090  
Tel: (800) 323-7790  
Tel: (847) 459-9500  
Fax: (847) 459-9515

**Dallas, TX**  
**Robco, Inc.**  
1523 Crescent Drive  
Carrollton, TX 75006  
Tel: (972) 242-3300  
Fax: (972) 245-2328

**Denver, CO**  
**U.S. Tsubaki, Inc.**  
5100-K Fox Street  
Denver, CO 80216  
Tel: (800) 352-4315  
Fax: (626) 913-5042

**Los Angeles, CA**  
**U.S. Tsubaki, Inc.**  
18031 Cortney Court  
City of Industry, CA 91748  
Tel: (800) 352-4315  
Tel: (626) 913-1344  
Fax: (626) 913-5042

**Philadelphia, PA**  
**U.S. Tsubaki, Inc.**  
2321 N. Penn Road  
Hatfield, PA 19440  
Tel: (800) 258-3847  
Tel: (215) 997-9170  
Fax: (215) 997-9179

**Portland, OR**  
**U.S. Tsubaki, Inc.**  
14157 N.E. Airport Way  
Portland, OR 97230  
Tel: (800) 352-4315  
Fax: (626) 913-5042

## Manufacturing Facilities

**Bennington, VT**  
**U.S. Tsubaki, Inc.**  
119 Bowen Road  
Bennington, VT 05201  
Tel: (800) 451-4441  
Tel: (802) 447-7561  
Fax: (802) 447-0755

**Holyoke, MA**  
**U.S. Tsubaki, Inc.**  
821 Main Street  
Holyoke, MA 01040  
Tel: (800) 628-9037  
Tel: (413) 536-1576  
Fax: (413) 534-8239

**Sandusky, OH**  
**U.S. Tsubaki, Inc.**  
1010 Edgewater Drive  
Sandusky, OH 44870  
Tel: (800) 537-6140  
Tel: (419) 626-4560  
Fax: (419) 626-5194

**Tsubaki of Canada Limited.**  
1630 Drew Road,  
Mississauga  
Ontario, Canada L5S 1J6  
Tel: (800) 263-7088  
Tel: (905) 676-0400  
Fax: (905) 676-0904

**Distributed by:**

NOTE: IN ACCORDANCE WITH THE POLICY OF U.S. TSUBAKI, INC., TO CONSISTENTLY IMPROVE ITS PRODUCTS, THE SPECIFICATIONS IN THIS BROCHURE ARE SUBJECT TO CHANGE WITHOUT NOTICE. **FOR CURRENT TERMS AND CONDITIONS OF SALE, SEE OUR CURRENT PRICE LIST.**